

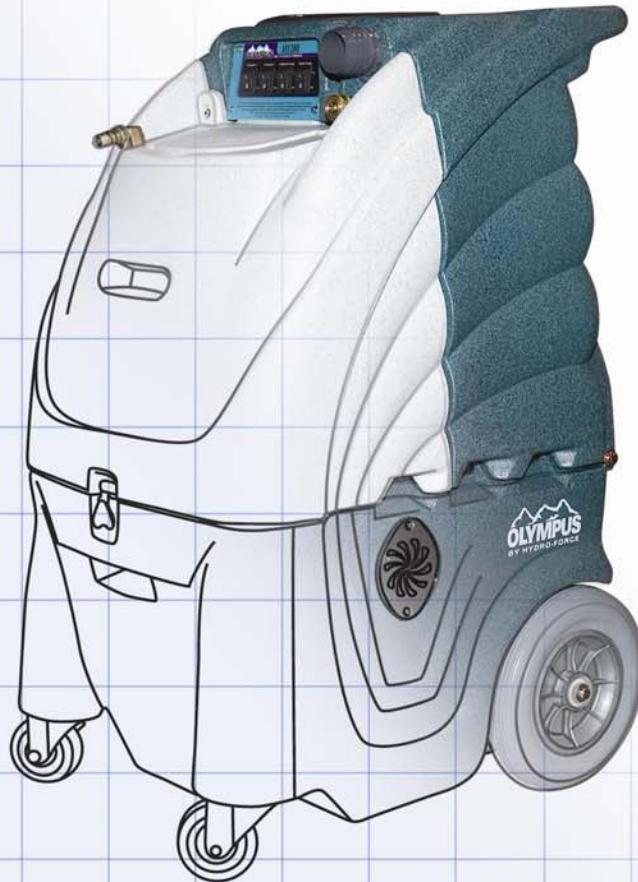

HYDRO-FORCE™

OLYMPUS M3-200 OPERATING MANUAL



© Copyright Hydro-Force 2005

Olympus M3-200 Operating Manual
TABLE OF CONTENTS

<u>TOPIC</u>	<u>PAGE #</u>
• Introduction	3
• Technical Specifications	4
• Optional Equipment	5
<u>SECTION 1: Operational Safety</u>	
• Electrical Safety	6
• Mechanical Safety	7
<u>SECTION 2: Operation Procedures</u>	
• Electrical Supply	8
• Water Supply & Chemicals	9
• Chemical Metering Tips	10
• Water Supply	11
• Pump Priming	12
• Solution & Vacuum Hoses	13
• Pump-Out System	14
• Pressure Adjustments	15
• Shutdown Procedures	16
• Troubleshooting	17-19
• Solution Flow Path	20
• Wiring Diagrams	21
<u>SECTION 3: Maintenance/ Technical</u>	
• Maintenance	25
• Drawings & Parts Lists	
○ Pump	33
○ Pressure Regulator	34
○ Auto-Fill - optional	35
○ Solution Tank	36
○ Waste Tank	39
○ Base & Vacuum System	42
○ Base, Pumps, Components	43
• Warranty	44

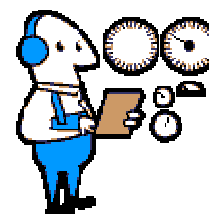

Introduction

Congratulations on your purchase of the Hydro-Force Olympus M3-200. The M3-200 is designed to give truckmount-level performance in a portable machine that combines versatility with ease of transport. Years of experience, engineering, and planning have gone into the design and manufacturing of the M3-200. We take a great deal of pride in the M3-200; our goal is no less than your complete satisfaction.

This manual will provide users with the knowledge required to operate the Olympus M3-200 safely, to understand how to properly operate and maintain the machine, and to ensure that the equipment operates at its maximum performance level.

All users must read and understand this manual completely before operating the machine.

Always maintain this manual in legible condition adjacent to the Olympus M3-200, or place in a secure location for future reference.

Any questions pertaining to the operating or servicing of this unit should be directed to your nearest Hydro-Force distributor.

This manual is written specifically for the Olympus M3-200 portable extractor units manufactured by:

Hydro-Force
4282 South 590 West
Salt Lake City, UT 84123
801-268-2673
801-268-3856 FAX

Information in this manual is subject to change without notice and does not represent a commitment on the part of Hydro-Force or its parent or affiliated companies.

Technical Specifications

M3-200 High Performance Extractor

Height: 38"

Length: 28"

Width: 19-1/2"

Weight: 93 lbs.

Solution Tank Capacity: 12 gallon

Recovery Tank Capacity: 12 gallon

Solution Pump: Pump-Tec #114T pump with 1.5amp Motor
200 psi – 2.00 - 0.67 gpm

Vacuum Motors: Two AMETEK Lamb 5.7" diameter – tangential discharge
Three stage – Mounted in series

Power Draw: Cord #1 – 10.40 wide open / 6.70 full load
(Add 5 amps on machines with Auto Pump-out System)
Cord #2 – 11.90 wide open / 8.20 full load

Standard Equipment

M3-200 High Performance Extractor

Carpet Wand: AW29XL - Stainless Steel S-Bend Dual Jet Wand

Vacuum Hose: 25' X 1-1/2" with 1-1/2" cuff & 2" cuff

HP Solution Hose: 25' x 1/4" with 1/4" male / female quick connects

Pump Priming Hose: 12" x 1/4" with 1/4" male quick connect

Power Cords: 2 – 25' x 12gauge with male & female plug ends

Additional / Optional Equipment

Auto Fill System with chemical draw:

Metering Tip Kit:

Auto Pump-out System:

Pump-out Hose:

Hydro-Filter Inline Filter:

Replacement Bags for Hydro-Filter:

Hydro-Force Injection Sprayer – Low pressure:

Hydro-Force Revolution Sprayer – Low pressure:

3.5" Hydry Upholstery Tool:

4.5" Hydry Upholstery Tool:

3.5" Hydry Deluxe Upholstery Tool:

4.5" Hydry Deluxe Upholstery Tool:

1-1/2" Vacuum Hose: (Sold per foot – No cuffs)

2" cuff for 1-1/2" Vac Hose:

1-1/2" cuff for 1-1/2" Vac Hose:

2" Hose Connector PVC:

1-1/2" Hose Connector PVC:

HP Solution Hose: (Does not include Quick Connects)

1/4" Male Quick Connect:

1/4" Female Quick Connect:

Power Cord 25' x 12gauge w/male & female plugs

Power Cord 50' x 12gauge w/male & female plugs

M012

PDE001

M016

AH65

AC11

AC11A

AS12

AS12R

AW50A

AW51A

AW50D

AW51D

AH36

AH46

AH42

AH76

AH74

AH79D

100009

100008

1696-6412

1696-6412



AW50



AW50D



AS12



AS12R

Safety

CAUTION! This machine is an electrical appliance. Care must be taken to reduce the risk of electrical shock.

- **READ AND UNDERSTAND ALL INSTRUCTIONS BEFORE OPERATING THE M3-200.**
- To reduce the risk of property damage or injury, repairs to electrical systems should only be performed by experienced technicians. Contact your distributor for assistance.
- Unplug machine power cord from outlet before performing any repairs on the extractor.
- Plug unit into grounded outlets only. Do not remove ground prong from plug. **Use of a Ground Fault Interrupting (GFI) device will reduce the risk of electrical shock.**
- Do not use the M3-200 outdoors, in standing water or on wet surfaces.
- Do not store the M3-200 in wet conditions.
- If extractor is leaking, unplug machine power cords from outlets before approaching or touching machine.
- Do not unplug power cord by pulling on the cord. Grasp the plug when unplugging the cord.
- Do not pull the extractor by the cord.
- If cord or plug is damaged, do not use cord. Replace with new cord or repair as needed before use.
- The power cords used must be able to handle an electrical load of 20amps each.
- The two power cords must be plugged into separate circuits during operation. Each cord can be on a 15amp or 20amp circuit. If the M3-200 has an Auto Pump-Out system Cord #1 must be on 20amp circuit. The use of a Breaker Buddy (Hydro-Force part number AX49) will ensure that the two cords are operating on different circuits (see page 8 for details.)

WARNING! This machine must be protected from conditions which may damage the pump, tank, hoses and other components.

- **Freezing of water in this machine will cause serious damage.** The M3-200, solution hoses, and tools must be protected from freezing temperature. Store, transport, and use this equipment only in temperatures well above freezing. (32°F or 0°C). If you suspect the M3-200 has been frozen, do not plug in or turn on machine until you are sure it has thawed completely.
- If the equipment cannot be stored or transported in a warm environment, it can be guarded from freezing by running an anti-freeze solution through the incoming water lines, chemical feed system, solution pump, solution lines, tools and pump-out pump. The machine is filled at the factory with anti-freeze to eliminate damage during shipment in cold weather.
 - The anti-freeze solution must be completely flushed from the machine before it is returned to service.
- The M3-200 must not be used to pick up flammable or combustible materials or used in areas where these materials may be present.
- Solvent-based or water-based solutions containing solvents may damage the pump, hoses, and other components. Do not assume chemical compatibility. Contact your distributor or Hydro-Force if you have questions regarding the compatibility of your chemicals with the machine.
- Do not clean with solutions that are at temperatures above 130°F.
- Rinse the solution tank, chemical system, and pump with fresh water after each day's use.
- Do not allow pump to run dry. Always maintain adequate solution level to supply solution pump.
- HP hoses may rupture if worn or damaged. Do not use HP solution hoses if hose covering is cut, bulging, or otherwise damaged. Examine HP solution hoses daily and replace or repair hoses as needed.
- Rinse tank and store the M3-200 with the recovery tank lid open. With Auto-Pump-out Option - Use a Hydro-Filter and clean the recovery tank daily to keep pump-out pump from becoming clogged.
- Keep Vacuum Inlet Filter clean and check float ball for proper operation. Do not operate the M3-200 without the Vacuum Inlet Filter in place. **Use defoamer to eliminate foam build-up during cleaning and prevent foam/moisture from entering vacuums.**

*****Use common sense to protect yourself and others while using this equipment.*****

- Keep pets and children away from the machine when in use.
- Keep all body parts, hair, and loose clothing away from openings and moving parts. Always wear appropriate clothing and safety equipment when operating unit.
- Use extra care when cleaning on stairs. Wet carpet on stairs can be slippery.
- Do not move the M3-200 up or down stairs when tanks are full of water. Drain solution and recovery tanks before moving unit up or down stairs. Lift using only the appropriate handles.
- Water may be spilled, drip, or be exhausted from vacuums during operation. Place unit in area where water will not cause damage or use drop cloth to protect surfaces.

Operation Procedures

Knowledge of the proper operation of the M3-200 is required to ensure user safety and efficient performance of the extractor.

SET UP AND OPERATION

1. Electrical Cords:

Two 25' power cords are supplied with the Olympus M3-200. Cord #1 powers Vacuum Motor #1 (and Waste Pump if equipped with optional Auto Pump-out System.); Cord #2 powers the high pressure Solution Pump and Vacuum Motor #2. The amperage required by each cord requires that the two cords be plugged into separate 15amp or 20amp circuits. (With Auto Pump-out System Cord #1 requires a 20amp circuit.)

Plug the two power cords into two outlets from different circuits.

If you are not sure if you are connected to separate circuits, use a Breaker Buddy (item # AX49), available from Hydro-Force, to test your circuits in the following manner:

- Plug the cords into the two outlets being tested, and then plug the Breaker Buddy into the two cords.
- If the green indicator light fails to light, you may be on the same circuit and must select a different plug for one of the cords.
- If the green indicator light comes on, you are plugged into two different circuits; connect the cords to the machine and proceed with your set-up procedure.

If a circuit breaker trips during operation, reset the breaker and move the cord to another outlet as needed.



Cord #2

Cord #1



Power Cord – 1696-6412
25' – 12 gauge M-F Plugs



Breaker Buddy – AX49

2A. Water Supply & Chemical Mixing– Manual Fill:

- Pour up to 12 gallons of hot water into the solution tank at the front of the machine. **The water temperature cannot exceed 130°F.**
- Measure and add the appropriate amount of the desired liquid chemical to the water in the solution tank. The amount of chemical will vary depending on the type of chemical used, the amount of water in the tank, and the material being cleaned; consult the chemical packaging for specific mixture ratios.
- Powdered chemicals should be dissolved in water before adding to the water in the solution tank.

DO NOT RUN OUT OF WATER WHILE USING THE MACHINE! Ensure that the tank contains enough water to complete each job. If the water level is low: stop cleaning, turn off the pump, and refill the tank. Running the pump dry will damage the pump and void the warranty.



Pour appropriate amount of hot water into solution tank



Add appropriate amount of chemical to water in solution tank

2B. Water Supply & Chemical Dilution – Optional Auto-Fill System:

- The chemical dilution rate is controlled by the metering tip, and the dilution rate can only be changed by changing the metering tip (See “How to Change the Metering Tip” on Page 10 for instructions.)

Chemical Feed Setup:

- Remove the chemical feed hose from the solution tank.
- Place the end of the hose into a container of liquid chemical.
- If the tip is removed, and the proportioning system operated with no tip, the dilution rate will be 8:1 (the equivalent to adding 16-1/4oz of chemical to each gallon of water.)
- The standard tip used with the M3-200 is the turquoise tip with a dilution rate of 256:1. This means that for each gallon of water flowing into the machine, 1/2 ounce of chemical will be added.
- **If a fresh water rinse with no chemical is desired, simply leave the chemical feed hose inside the solution tank.**

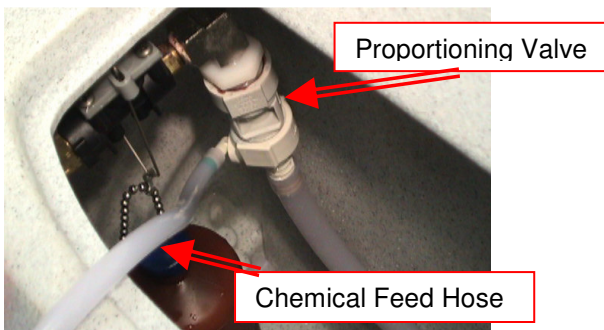

How to Change the Metering Tip:

- Remove the chemical feed hose from the barb on the side of the proportioning valve.
- Unscrew and remove the old tip.
- Screw in the proper tip for your chemical tip and place the hose back on the barb

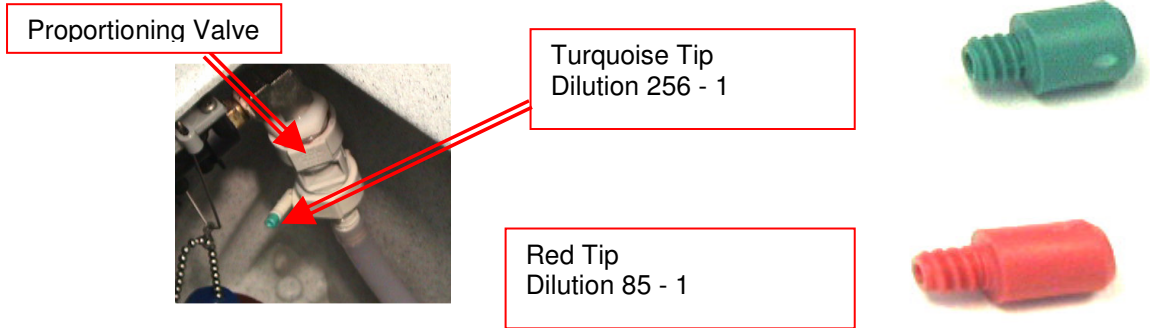

Metering Tip Kit – PDE001

Metering Tip Kit (Hydro-Force Item# PDE001) contains 14 different colored metering tips, allowing dilution rates from 11:1 up to 427:1. Refer to the chart below to select the tip that meets the dilution rate for your chemical application.

- For example: if you require 1-1/2 ounces of chemical per gallon of water, change to the red metering tip with the dilution rate of 85:1.
- The dilution rates are based on chemicals with water-like viscosity. Thicker (more viscous) chemicals will dilute at a different rate.
- For powdered chemicals, a liquid concentrate must be made. Mix the concentrate according to the manufacturer’s directions, and then select the appropriate metering tip.
- Contact your distributor or Hydro-Force if you have questions about your chemical.

Metering Tip Application Chart:



TIP COLOR	CHEMICAL DILUTION RATES	
	OZ / GAL	(RATIO)
TAN	0.30	(427:1)
ORANGE	0.40	(320:1)
TURQUOISE	0.50	(256:1)
PINK	0.75	(170:1)
LIGHT BLUE	1.00	(128:1)
BROWN	1.12	(114:1)
RED	1.50	(85:1)
WHITE	1.75	(73:1)
GREEN	2.00	(64:1)
BLUE	2.50	(51:1)
YELLOW	3.75	(34:1)
BLACK	5.00	(26:1)
PURPLE	8.50	(15:1)
GRAY	11.50	(11:1)
NO TIP	16.25	(8:1)

Water Supply:

- Once the correct metering tip is in place:
 - Connect the Auto-Fill Water Supply Hose to the water inlet (the male quick-connect on the front of the machine.)
 - Connect the other end of the hose to a water faucet, and then turn on the water.
- Hot water can be used as long as the temperature does not exceed 130°F.
- Faucet adapter kits (Hydro-Force item #AX21 & AX22) are available that allow connection to different types of faucets if needed.

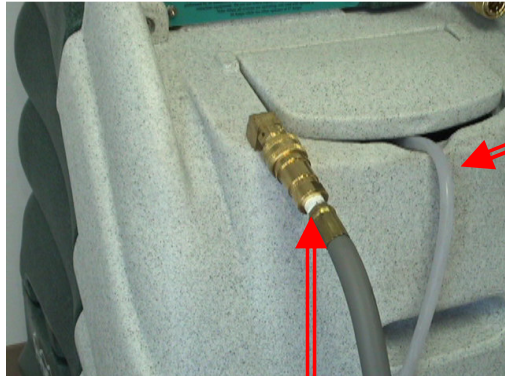

Chemical Feed Hose



Connect the Auto-Fill Water Supply Hose to a faucet and turn on the water

Connect the Auto-Fill Water Supply Hose to Solution Inlet (Male quick connect on the front of the machine.)
3/8" id X 25' with F Quick Connect & F Garden Hose Fitting

To adjust the water level in the solution tank:

- Turn off the water supply.
- Adjust the length of the chain connecting the float bottle to the float valve.
- Snap the beaded chain off the connector on the valve.
 - Move the bottle down to decrease the water level.
 - Move the bottle up to increase the water level.
- Snap the chain back into the connector.
- Turn the water supply back on.

If the chemical is not drawing, or if the tank is not filling or is overflowing, refer to the trouble shooting guide, or contact your distributor for assistance.

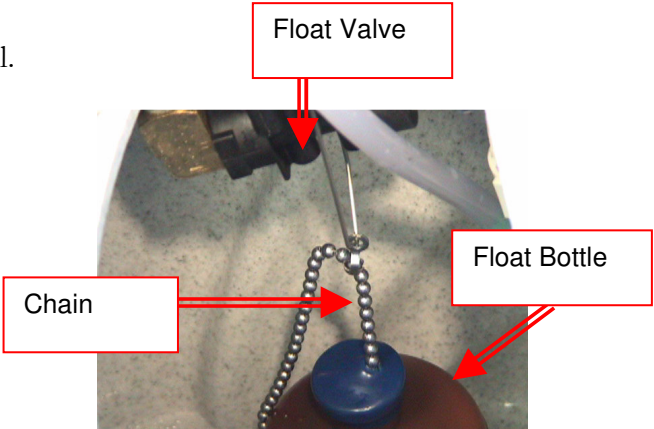

3. Priming the High-Pressure Pump:

Once water is in the solution tank, the high-pressure solution pump must be primed:

- Connect the short prime hose to the solution outlet (female quick-connect on the front of the machine.)
- Direct the end of the hose back into the solution tank and turn the solution pump switch to the ON position.
- When a steady stream of water is flowing out of the hose, turn off the solution pump, remove the hose, and proceed with the set-up procedures.

If the pump does not prime quickly, the vacuum may be used to aid priming:

- Direct the end of the short prime hose into the vacuum barb on the front of the machine.
- Turn on one or both of the vacuum motors
- Turn on the solution pump.
- Cup a hand around the hose & barb to increase the vacuum suction on the hose.
- When water is flowing out of the hose, direct the hose to the solution tank and turn off the vacuum motors to ensure the flow continues when the vacuum is removed.
- When the flow is steady, turn off the solution pump, remove the hose, and proceed with machine set-up procedures.

If the pump still does not prime, or if flow is low or unsteady, check the hose from the solution tank to the pump (as well as the inline filter) for clogging, kinks, or restrictions. Clean or replace hose and/or filter and repeat the priming procedure.

If you are having trouble with the pump, refer to the trouble shooting guide or contact your distributor for advice or assistance.



Pump Prime Hose
NM5080



Place end of prime hose and use vacuum to prime the solution pump.

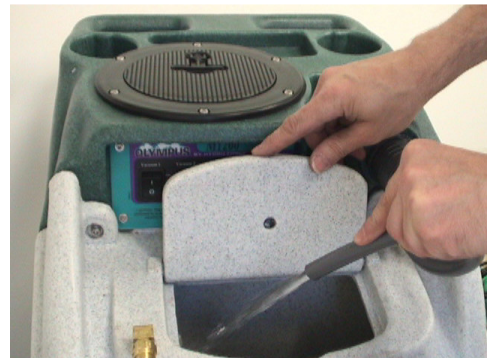

Keep prime hose connected and run pump until flow is strong and steady

4. Connection of Solution Hose:

Connect the high pressure solution hose to the solution outlet (female quick connect on the front of the machine). Connect the other end of the hose to the male quick connect on the cleaning tool. When you are ready to start cleaning, turn the solution pump switch to the ON position



HP Solution Hose Assembly – AH79D
1/4" id X 25' with M-F Quick Connects

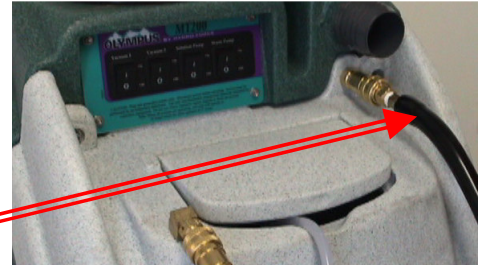

Connect the male end of the HP Solution Hose Assembly to the female solution outlet fitting on the machine. Connect the female end to the cleaning tool.

5. Connection of Vacuum Hoses:

A 1-1/2" x 25' Vacuum Hose is included with the M3-200. The 2" cuff on the 25' vacuum hose is connected to the Vacuum Barb on the front of the machine. The other end with the 1-1/2" cuff is connected to the cleaning tool.

When ready to begin cleaning, turn both vacuum switches to the ON position. While the M3-200 can be operated with only one vacuum for cleaning delicate fabrics, in most situations you will turn both vacuum switches ON.

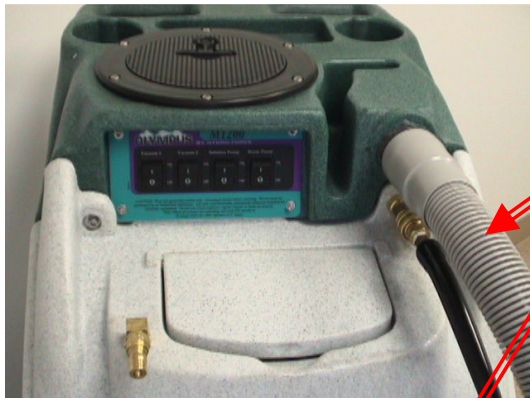

Vacuum Hose
1-1/2" x 25' with 2" & 1-1/2" cuffs



6. Optional Auto Pump-out System - Connection of Pump-out Hose:

The pump-out hose is a 50' section of 3/4" garden hose.

- Remove the cap from the pump-out outlet fitting on the back of the machine.
- Connect the pump-out hose to the outlet fitting.
- Place the other end of the hose in a commode or drain connected to the sanitary sewer system.
- Secure hose end to prevent movement during pumping.

Use defoamer to prevent foam build-up in recovery tank during cleaning and to keep foam/moisture from entering vacuums.

When ready to begin cleaning, turn the waste pump switch to the ON position.

- **Do not turn on waste pump switch unless pump-out hose is connected and has been routed to a proper drain.**



Pump-out Hose – AH65
3/4" id X 50' with M-F Garden Hose Fittings



Connect the Female Garden Hose Fitting end of the Pump-out Hose to the outlet fitting on the back of the recovery tank. Place the other end of the pump-out hose in a sanitary drain.

6A. Waste Tank Shutoff:

If not equipped with an Auto Pump-out System or not using the waste pump-out, the pump-out hose does not need to be connected. When the recovery tank fills during cleaning, the float ball assembly in the vacuum inlet filter will rise and will automatically shut off the vacuum air flow to prevent the recovery tank from overflowing and waste water from getting into the vacuums. When this occurs:

- Immediately shut off the vacuum switches.
- Drain the recovery tank.
 - Turn off the pump switch while draining the tank.
 - Turn pump switch back upon resumption of cleaning.
- Close the drain valve and turn the vacuum switches back on when ready to resume cleaning.

If the pump-out or vacuum shutoff is not working properly, refer to the trouble shooting guide or contact your distributor for advice or assistance.



Float Shutoff Assembly – NM5037

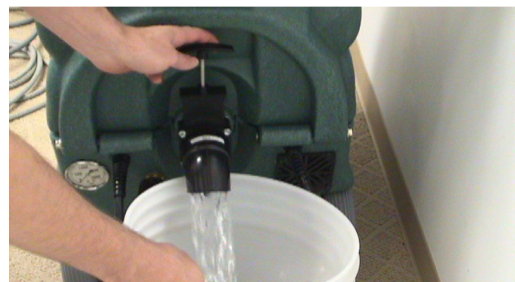

Draining the Recovery Tank

7. Pressure Adjustment:

The pressure regulator of the M3-200 is not adjustable. It is preset at the maximum pressure setting of 200psi; however, the highest pressure attained is dependent on the amount of water flow at the tool. The maximum flow rate to maintain 200psi is 0.67gpm. This means to maintain 200psi the largest jet size is for a single jet tool is 03 or two 015 jets on a dual jet cleaning wand.

- Smaller jets and lower flow will allow for higher pressure at the tool.
- Larger jets and higher flow will lower the maximum pressure attained at the tool.

The number found on the face of the jet, such as 8003, 95015 or 11004, states the size and shape of the jet orifice. The first two or in some cases three numbers (80, 95 & 110) represent the spray angle. The last two or in some cases three numbers (03, 015 & 04) represent the orifice size. The orifice size number represents the flow through that jet at 40psi in tenths of a gallon per minute. Thus a small orifice such as 015 will flow 0.15gpm at 40psi. A larger orifice such as 04 will flow 0.40gpm at 40psi. (See chart below.)

Different jets with the same spray angle (8001, 8003 & 8004) can have different orifice sizes.
Different jets with the same orifice size (80015, 95015 & 110015) can have different spray angles.

Choose the jets that will meet the flow rate at your desired pressure and have the spray pattern suited to your tool and type of cleaning.

If maintaining pressure becomes a problem, refer to the trouble shooting guide or contact your distributor for advice or assistance.

Tee Jets and Vee Jets

Orifice Size	Equiv. Dia. in inches	Flow Capacity (Gallons Per Minute)						
		40psi	60psi	100psi	200psi	300psi	500psi	1000psi
01	0.026	0.10	0.12	0.16	0.22	0.27	0.35	0.50
015	0.031	0.15	0.18	0.24	0.34	0.41	0.53	0.75
02	0.036	0.20	0.25	0.32	0.45	0.55	0.71	1.00
03	0.043	0.30	0.37	0.47	0.67	0.82	1.10	1.50
04	0.052	0.40	0.49	0.63	0.89	1.10	1.40	2.00
05	0.057	0.50	0.61	0.79	1.10	1.40	1.80	2.50
06	0.062	0.60	0.73	0.95	1.30	1.60	2.10	3.00
08	0.72	0.80	0.98	1.30	1.80	2.20	2.80	4.00
10	5/64	1.00	1.20	1.60	2.20	2.70	3.50	5.00
15	3/32	1.50	1.80	2.40	3.40	4.10	5.30	7.50

To determine the flow rate of tools with multiple jets, add the flow of each jet together to calculate the total flow at the desired pressure.

Shutdown Procedures:

- If using the auto-fill system, turn the water supply off before finishing each job. This will allow use of the water and chemical already in the tank, and will reduce the amount of excess water to be disposed of later.
- When finished cleaning, turn off all switches.
- If the auto-fill system was used and there is still water in the solution tank, push the float down to release the water inlet hose pressure before disconnecting the hose from the faucet. Disconnect the water inlet hose from the quick-connect on the front of the machine.
- Disconnect the solution hose and vacuum hose from the cleaning tool. Pull valve trigger to release pressure from the hose before disconnecting solution hose from cleaning tool.
- If used disconnect the Hydro-Filter from the vacuum hoses and clean the filter as needed. Replacement filter bags are available (AC11A.)
- Disconnect the vacuum hose and solution hose from the machine.
- If water remains in the solution tank, use the vacuum and vacuum the excess water from the tank.
- If the auto-fill system was utilized, place the chemical feed hose back into the solution tank.
- If the waste pump-out system was used:
 - Turn the waste pump switch “ON” to pump out any remaining water from the recovery tank.
 - Turn switch off, remove the pump-out hose from the outlet fitting and replace the cap.
 - Roll up hose toward drain to remove remaining water from hose.
 - Connect ends of hose together to prevent dirty water from dripping from hose during transport.
- Disconnect the power cords from the outlets and from the machine.
- Remove the float shutoff assembly from the recovery tank and clean filter as needed. Replace shutoff assembly and tank lid.
- Drain any remaining water from the recovery tank and dispose in sanitary drain. Do not use the same bucket to drain the tank that you use to fill the tank.
- Roll up all hoses and cords.
Collect and store extractor, all tools, and accessories.

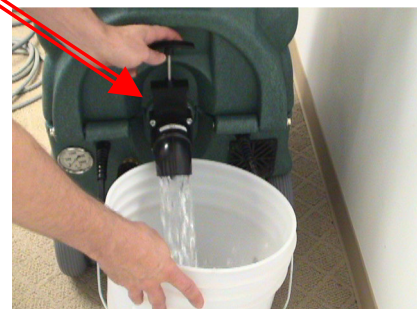

Troubleshooting

Troubleshooting – Olympus M3-200

Problem	Cause	Solution
Machine not turning on - No power	Building circuit breaker tripped.	Reset breakers or move cords to other outlets
	Faulty power cord	Replace cord (1696-6412)
	Faulty switches or internal wiring	Check wiring & test switches - Repair as needed *
Solution Pump not running	Building circuit breaker tripped.	Reset breakers or move cords to other outlets
	Faulty power cord	Replace cord (1696-6412)
	Faulty switches or internal wiring	Check wiring & test switches - Repair as needed *
	Pump circuit breaker tripped	Reset or replace circuit breaker
	Pump motor faulty	Replace pump motor (PT061)
	Pump seized - trips breaker	Repair or replace pump head & bearing - Check motor (PT050 or AP50)
Low Solution Pressure and/or Pulsation	Jets too large for pressure desired	Check jets size & flow rates use smaller jets or lower pressure
	Jets worn allowing too much flow	Replace jets
	Solution inlet filter plugged	Clean or replace filter
	Hose from solution tank restricted	Repair or replace hose
	Pump intake hose or fittings leaking	Repair or replace hose. Tighten clamps or replace fittings
	Pressure regulator sticking	Repair or replace pressure regulator (1683-5656)
	Pressure regulator faulty	Repair or replace pressure regulator (1683-5656)
	Filter screen or jets plugged on tool	Clean out filter or jets
	Solution tank empty	Add water to tank - Check & repair auto fill assembly
	Pump not primed	Perform pump priming procedure
	Pump faulty	Repair or replace pump (AP50)
	Tool valve faulty	Repair or replace valve
	Quick connects or hoses restricted	Clean out or replace quick connects and/or hoses
Can't connect solution hose to machine	Pressure in lines	Release pressure
	Quick connects faulty	Replace quick connects (100008, 100007)
	Wrong style/size quick connects	Replace quick connects to match connects on machine
<p>* To reduce the risk of fire electrical shock or injury repairs to wiring should only be performed by experienced service technicians. If you are not experienced in checking electrical wiring contact your nearest authorized service center to perform tests and repairs to wiring and switches.</p>		

Problem	Cause	Solution
Pump-out not working Optional Auto Pump-Out	Building circuit breaker tripped.	Reset breakers or move cords to other outlets
	Faulty power cord	Replace cord (1696-6412)
	Faulty switches or internal wiring	Check wiring & test switches - Repair as needed * (NM5008)
	Pump-out pump faulty	Replace pump-out pump (NM5053)
	Pump-out pump clogged	Clean pump-out - Keep recovery tank clean - Use Hydro-Filter
	Outlet check valve stuck	Clean or replace check valve
	Discharge hose restricted	Un-kink, clean out or replace hose
	Float switch stuck	Clean switch make sure float slides up & down easily
	Float switch faulty	Replace float switch (NM5054)
Vacuum Motor not running	Building circuit breaker tripped.	Reset breakers or move cords to other outlets
	Faulty power cord	Replace cord (1696-6412)
	Faulty switches or internal wiring	Check wiring & test switches - Repair as needed *
	Vacuum motor faulty	Replace vacuum motor (AV14)
Loss of Vacuum	Vacuum motor faulty	Replace vacuum motor (AV14)
	Vacuum motor gasket damaged	Replace gasket (PA010)
	Recovery tank lid gasket damaged	Replace gasket (NM5059)
	Drain valve open	Close valve
	Drain valve leaking	Repair or replace drain valve (PEA11)
	Vacuum motor hoses loose / leaking	Reconnect or replace vacuum motor hoses
	Vacuum hose or tool clogged	Clean out vacuum hoses and tool
	Vacuum hoses or cuffs leaking	Replace vacuum hoses, cuffs & connectors as needed
	Recovery tank full	Drain tank
	Float shutoff filter clogged	Clean float shutoff filter
	Ball stuck in float shutoff	Repair or replace float shutoff (NM5037)
	Pump-out Check Valve stuck open	Clean out or replace check valve(NM5052)
Recovery tank damaged	Replace recovery tank	
Chemical not feeding Optional Auto-Fill	Solution tank not filling	Check & repair auto fill assembly
	Chemical hose restricted	Un-kink, shorten, clean out or replace hose
	Filter screen plugged	Clean or replace filter (PDE100-11P)
	Low Incoming Water Pressure	Set chemical bottle on top of machine – Shorten Chemical hose – Find other water source.
	Wrong size metering tip	Change metering tip
	Chemical proportioner faulty	Replace chemical proportioner (PDE61-22-3)
	Check valve in filter faulty	Replace filter (PDE100-11P)
Tool won't spray - low or uneven spray	Jets clogged	Clean out or replace jets
	Inline filter clogged	Clean out or replace filter
	Jets worn	Replace jets
	Jets not aligned properly	Re-align jets
	Tool valve faulty	Repair or replace valve
	Quick connects or hoses restricted	Clean out or replace quick connects and/or hoses
<p>* To reduce the risk of fire electrical shock or injury repairs to wiring should only be performed by experienced service technicians. If you are not experienced in checking electrical wiring contact your nearest authorized service center to perform tests and repairs to wiring and switches.</p>		

Problem	Cause	Solution
Solution Tank not filling	Water source turned off	Turn on faucet or find other water source
	Float not on valve arm	Reconnect float to valve arm - Adjust to proper height/level
	Float valve faulty	Repair or replace float valve (NM5055)
Optional Auto Fill	Water hose restricted	Un-kink, clean out or replace hose
	Quick connects faulty	Clean out or replace quick connects (100008, 100007)
Solution tank overflowing	Float too heavy/ Filled with water	Replace float (PHY005-003)
	Float & chain tangled	Make sure float chain free & hanging properly
	Float too high	Adjust chain to set float at proper level
	Float valve faulty	Repair or replace float valve (NM5055)
Chemical Jug Filling with water - Overflowing	Foot valve in Filter stuck	Clean out foot valve and filter
	Foot valve in Filter faulty	Replace foot valve and filter (PDE100-11P)
Optional Auto Fill		
<p>* To reduce the risk of fire electrical shock or injury repairs to wiring should only be performed by experienced service technicians. If you are not experienced in checking electrical wiring contact your nearest authorized service center to perform tests and repairs to wiring and switches.</p>		

- Contact your distributor for additional troubleshooting assistance, to order parts, or for advice and assistance in performing necessary repairs.

M3-200

Solution Flow Path

Flow Path shown with optional Auto-Fill System M012

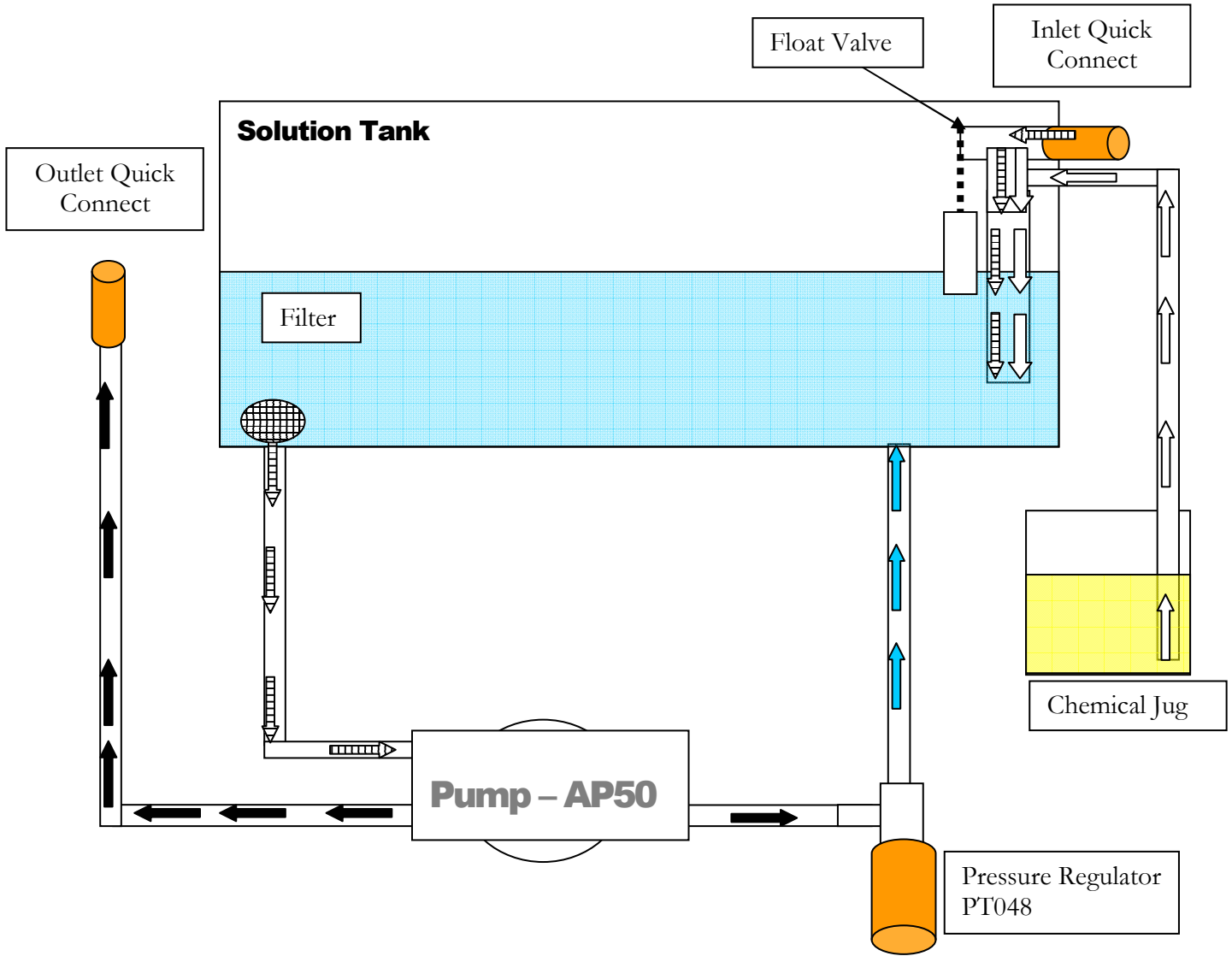

Denotes incoming water flow

Denotes Water flow in high pressure hose

Denotes by-pass water flow from pressure regulator

Denotes Chemical flow

M3-200

Wiring Diagram - Standard

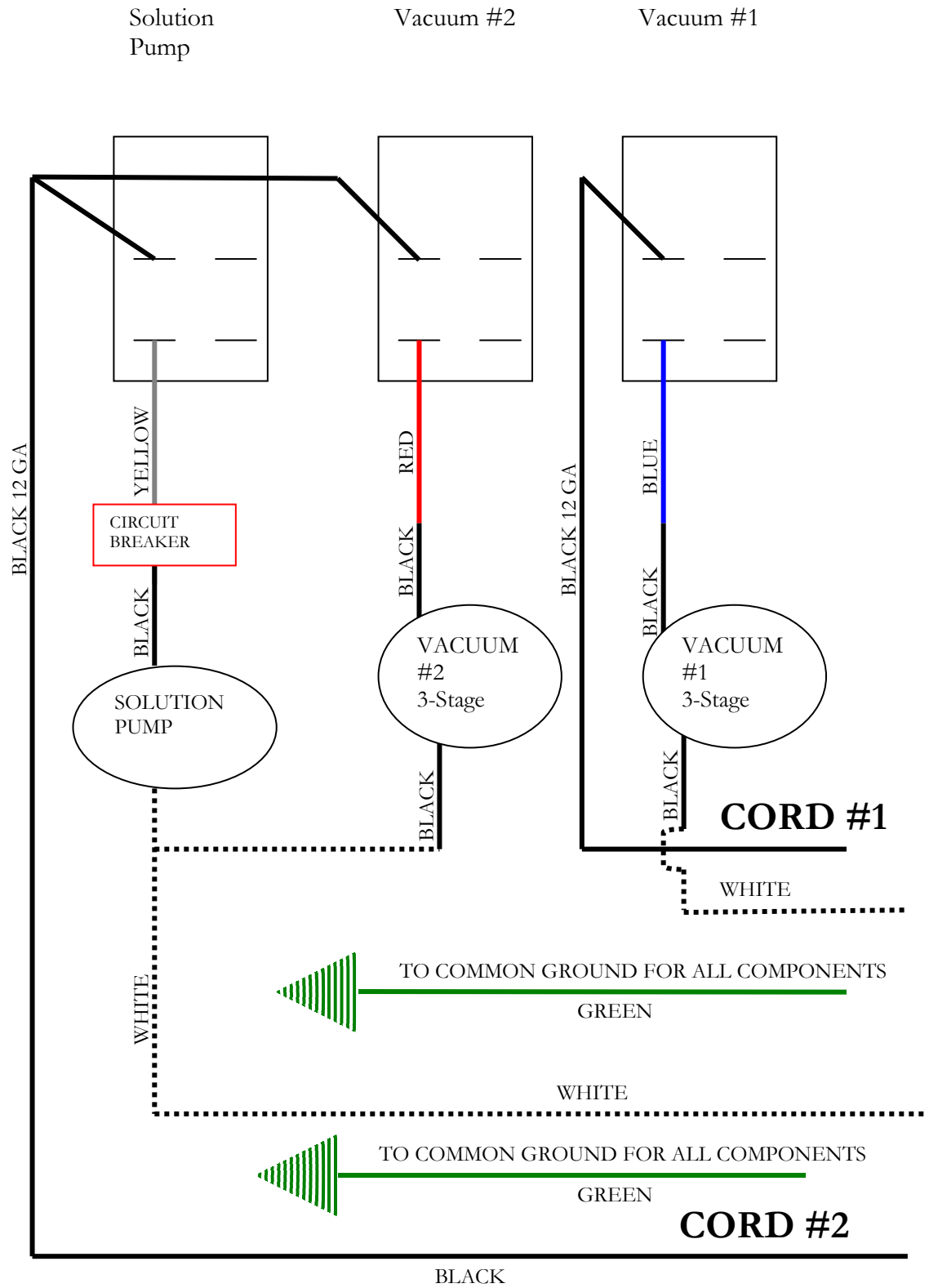

M3-200

Wiring Diagram

With Auto Pump-Out System

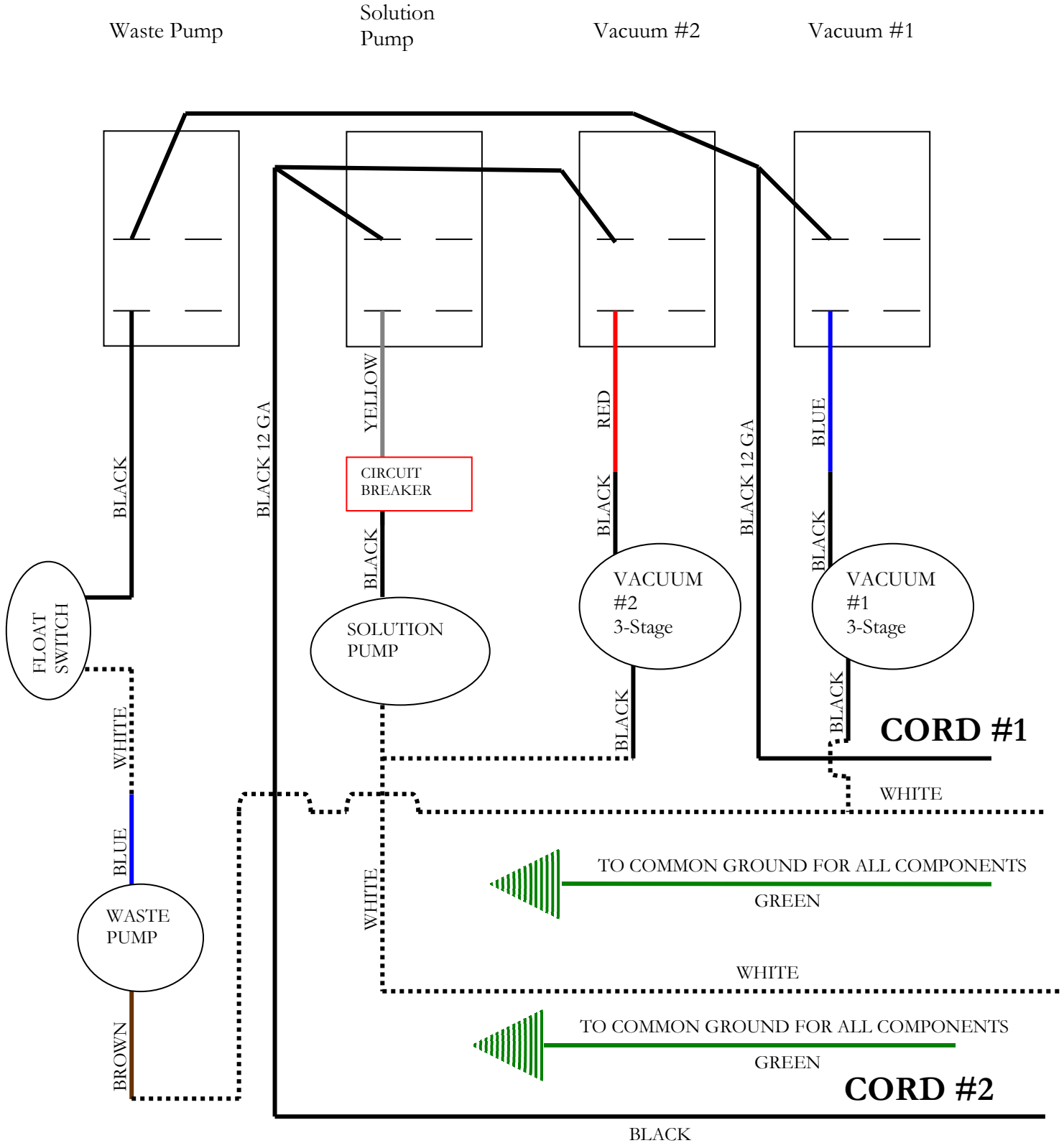

OLYMPUS M3-200 STANDARD SWITCH PANEL:

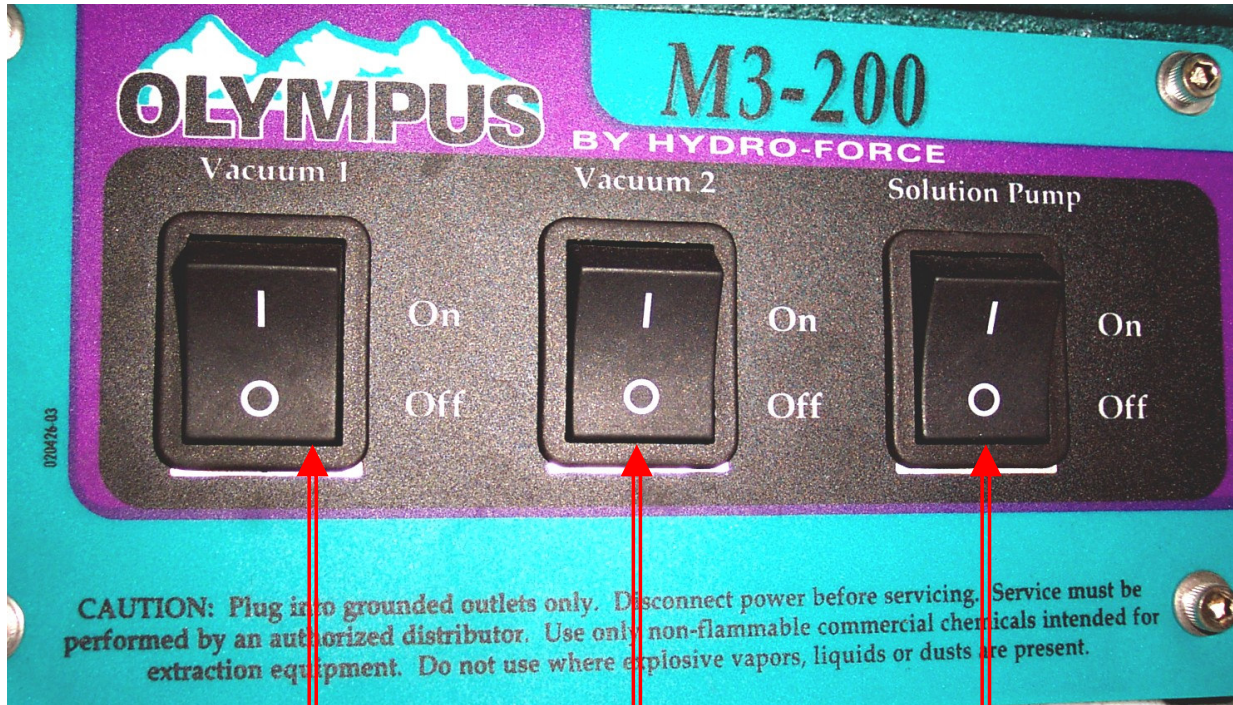

Vacuum #1 – Power from Cord #1.
When the switch is turned to the ON position power is supplied to the vacuum motor. (3-Stage Vacuum)

Vacuum #2 – Power from Cord #2.
When the switch is turned to the ON position power is supplied to the vacuum motor. (3-Stage Vacuum)

Solution Pump Switch – Power from Cord #2.
When the switch is turned to the ON position power is supplied to the solution pump motor. When not using solution (Extracting Only) do not turn this switch ON.

OLYMPUS M3-200 WITH AUTO PUMP-OUT SWITCH PANEL:

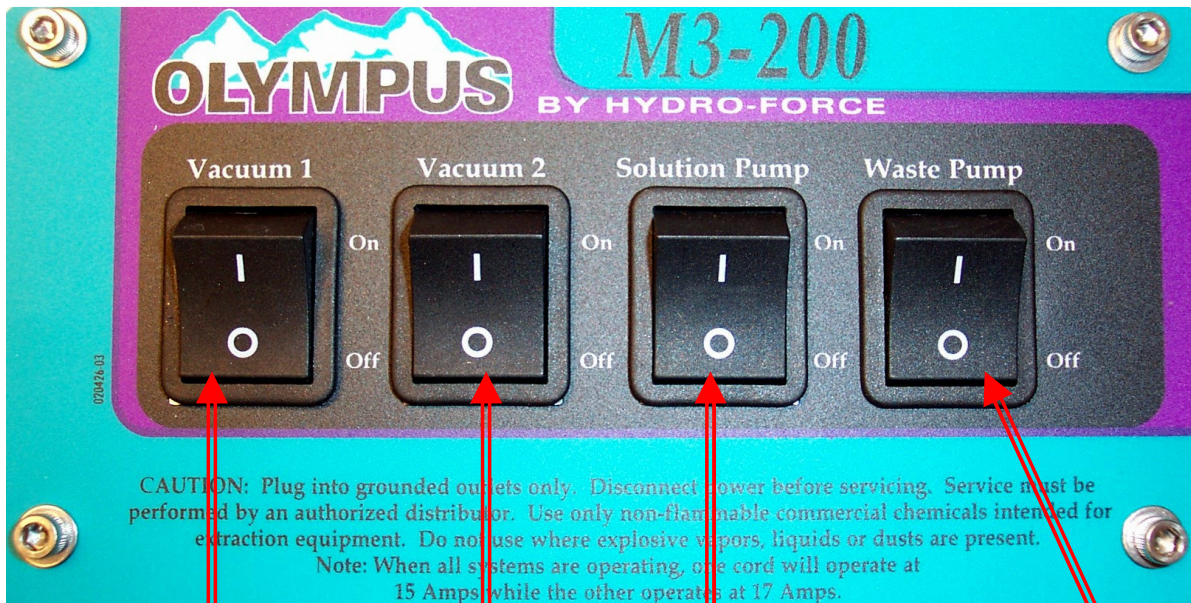

Vacuum #1 – Power from Cord #1.
When the switch is turned to the ON position power is supplied to the vacuum motor. (3-Stage Vacuum)

Vacuum #2 – Power from Cord #2.
When the switch is turned to the ON position power is supplied to the vacuum motor. (3-Stage Vacuum)

Solution Pump Switch – Power from Cord #2.
When the switch is turned to the ON position power is supplied to the solution pump motor. When not using solution (Extracting Only) do not turn this switch ON.

Waste Pump Switch – Power from Cord #1.
When switch is turned to the ON position, Waste Pump operation is controlled by the Float Switch in the Recovery Tank. Pump will remain off until water level rises to the point at which the float switch will turn the Waste Pump ON. Do not turn Waste Pump Switch ON unless a hose is connected to the Pump-out Outlet port.

Maintenance

Proper maintenance is required to keep the M3-200 operating properly, prevent downtime and to extend the life of your equipment.

WARNING: Disconnect electrical power before performing any service or maintenance inside machine base or before testing or repairing switches or power cords. Failure to do so may result in severe personal injury or death.

OPERATION	INTERVAL	Page #
CLEAN CHEMICAL FEED FILTER & FOOT VALVE (Machines with optional AUTO-FILL SYSTEM only)	Daily – After Each Job	24
CLEAN VACUUM SHUTOFF ASSEMBLY SCREEN	Daily – After Each Job	24
CLEAN HYDRO-FILTER (If so equipped)	Daily – After Each Job	25
RINSE OUT RECOVERY TANK	Daily	25
CLEAN WASTE PUMP (Machines with optional AUTO PUMP-OUT SYSTEM only)	Daily	26
FLUSH SOLUTION TANK AND PUMP	Daily	26
CLEAN PUMP-INLET FILTER	Weekly – As needed	27
FLUSH CHEMICAL SYSTEM (Machines with optional AUTO-FILL SYSTEM only)	Monthly	28
CLEAN DRAIN VALVE	As needed	31
STORAGE PREP – FREEZE PROTECTION	As needed	32

CLEAN CHEMICAL FEED FILTER & FOOT VALVE: With optional Auto-Fill System Only

The Filter & Foot Valve is on the end of the chemical feed hose that is placed in the chemical jug as part of the optional Auto-Fill chemical feed system.

Regularly examine the filter and clean as needed.

To test the Foot Valve:

- Remove the Filter & Foot Valve from the end of the chemical feed hose and rinse in fresh water.
- Blow through the valve from the filter side of the barb.
 - If the Foot Valve is functioning, air should move freely from the filter side, but will not flow from the barb side of the filter.
 - If valve is not functional, clean or replace as needed.

Heavy chemical build-up can be removed with a mild acid rinse and/or the use of a brush and compressed air.

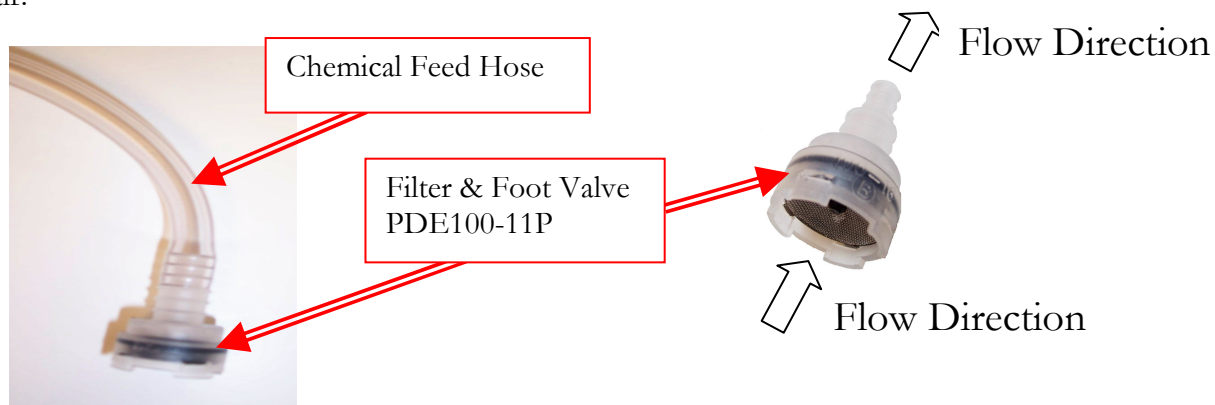

CLEAN VACUUM SHUTOFF ASSEMBLY SCREEN:

Inside the recovery tank, on top of the stand pipe, is the Vacuum Shutoff Assembly. It functions to prevent debris and water from being sucked into the vacuum motors. Operating the M3-200 without the Vacuum Shutoff Assembly or with a poorly maintained assembly will greatly decrease the life of the vacuum motors and will void the warranty.

If debris builds up on this filter, it will reduce the vacuum air flow and may cause a significant decrease in the rate of water recovery. If debris prevents the float ball from moving or seating inside the assembly, it may not stop the airflow when the tank fill with water, and the water will be sucked into the vacuums and blown out the exhaust. **Use defoamer to prevent foam or moisture from entering vacuums.**

To clean:

- Twist to loosen and pull the assembly off of the stand pipe.
- Pull fibers and lint off and rinse with clean water.
- Push the assembly back onto the stand pipe and replace the recovery tank lid.



Vacuum Shutoff Assembly
NM5037



CLEAN THE HYDRO-FILTER: (Optional Accessory)

Build-up of debris in the filter bag of the Hydro-Filter will reduce the vacuum air flow and may cause a significant decrease in water recovery. A torn filter bag will allow debris past the filter and into the recovery tank. This debris can clog the Waste Pump and the Vacuum Shutoff Assembly. **The Hydro-Filter must be examined and cleaned regularly to keep the M3-200 functioning properly:**

- Push the latch lever and open the Hydro-Filter lid.
- Remove the filter bag. Examine the bag and clean or replace as needed.
- Rinse the body of the Hydro-Filter with clean water.
- Examine the o-ring seal and replace as needed.
- Re-install the new or cleaned bag.
- Close lid and secure latch.

Repair parts are available for the Hydro-Filter:
Filter Bag: AC11A
Parts Kit: AC11B – (Includes Latch, O-ring & screws.)
Lid: AC11D

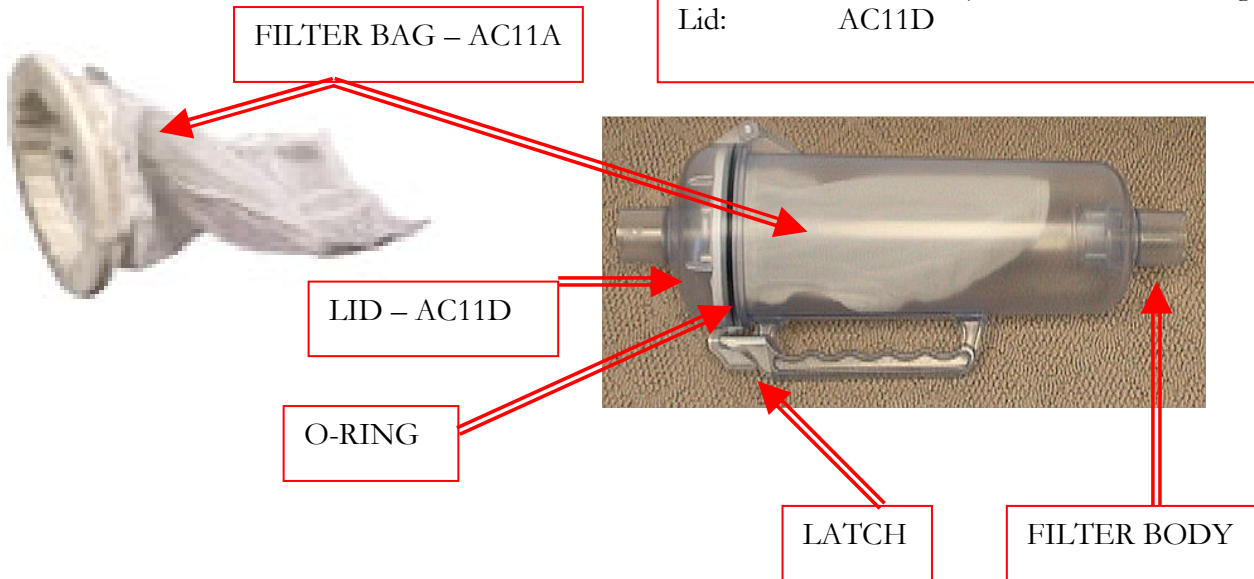

RINSE OUT RECOVERY TANK:

Build-up of fine silt and debris can damage the Waste Pump and Drain Valve. Clean out the tank on a regular basis to extend the life of these components as well as keep the tank and machine smelling better.

- Remove the recovery tank lid and open the drain valve.
- Place a bucket under the drain valve.
- Use a hose to rinse the dirt and debris out of the recovery tank.
- Close the drain valve and spray the tank with a deodorizer or disinfectant.
- Proceed to Waste Pump Cleaning and replace the recovery tank lid.
- Dispose of the dirty water and debris.



CLEAN WASTE PUMP-OUT PUMP: (With optional Auto Pump-Out System Only)

Build-up of fine silt inside the Waste Pump can clog the pump even if the pump is not used, so this maintenance procedure should be performed regardless of whether the Waste Pump has been used.

- After cleaning out the recovery tank, remove the cap and connect the Pump-Out hose to the Waste Pump outlet fitting on the back of the machine; run the hose to a drain..
- With Cord #2 plugged in, turn the Waste Tank switch to the ON position.
- Use a hose to fill the recovery tank to the point where the float switch turns the Waste Pump ON.
- Let the pump run until it pumps the level down to the point when the float switch shuts off the Waste Pump.
- Unplug the cord and turn the Waste Pump switch OFF.
- Open the drain valve and drain out the remaining water.
- Close the drain valve, replace the recovery tank lid, and dispose of the dirty water and debris.

FLUSH SOLUTION TANK AND PUMP:

- Pour two or three gallons of clean water into the solution tank.
- With Cords #1 & #2 plugged in, connect the pump prime hose to the solution outlet female quick connect.
- Direct the end of the prime hose into the recovery tank vacuum barb.
- Turn one or both of the vacuums ON and turn the solution pump ON.
- Let the pump run until most of the water has been pumped out of the solution tank. **Do not let the pump run dry. Turn the pump OFF before the water gets to the bottom of the tank.**
- Turn the vacuums OFF and disconnect the prime hose.
- Place a bucket under the drain valve; open the drain valve to drain the water out of the recovery tank.
- Close the drain valve and dispose of the water.



Pour 2 or 3 gallons of clean water into Solution Tank

If there is a heavy chemical build-up in the machine, hoses, or tools, a mild acid can be added to the rinse water in the previous procedure (REFER TO PHOTOS ON FOLLOWING PAGE.)

- After the pump has been primed, turn the solution pump switch OFF and turn the vacuums OFF.
- Remove the prime hose and connect the HP solution hose and tools.
- Turn the solution pump ON and direct the tool spray into a bucket. Let the pump run until most of the water has been pumped out of the solution tank. **Do not let the pump run dry. Turn the pump OFF before the water gets to the bottom of the tank.**
- Disconnect the solution hose and tool.
- Use the vacuum hose to vacuum the remaining acid solution out of the solution tank.
- Pour two or three gallons of clean water into the solution tank.
- Connect the pump prime hose to the solution outlet female quick connect.
- Direct the end of the prime hose into the recovery tank vacuum barb.
- Turn one or both of the vacuums ON and turn the solution pump ON. Let the pump run until most of the water has been pumped out of the solution tank. **Do not let the pump run dry. Turn the pump OFF before the water gets to the bottom of the tank.**
- Turn the vacuums OFF and disconnect the prime hose.
- Place a bucket under the drain valve and open the drain valve to drain the water out of the recovery tank. Close the drain valve and dispose of the water.

FLUSH SOLUTION TANK AND PUMP: (continued from previous page)

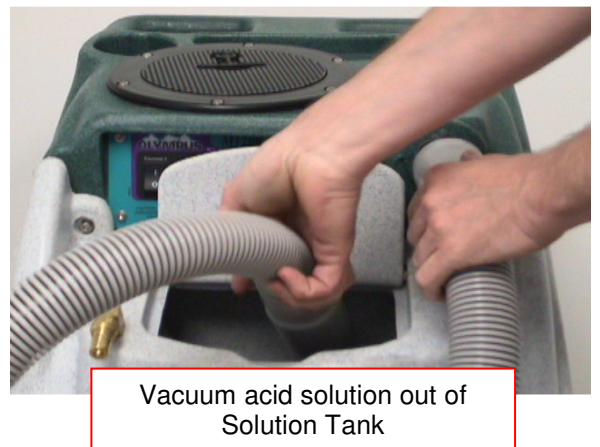

CLEAN PUMP INLET FILTER

A restricted Pump Inlet Filter can prevent the solution pump from providing adequate pressure for cleaning.

- Remove the stainless steel filter screen and clean as needed.

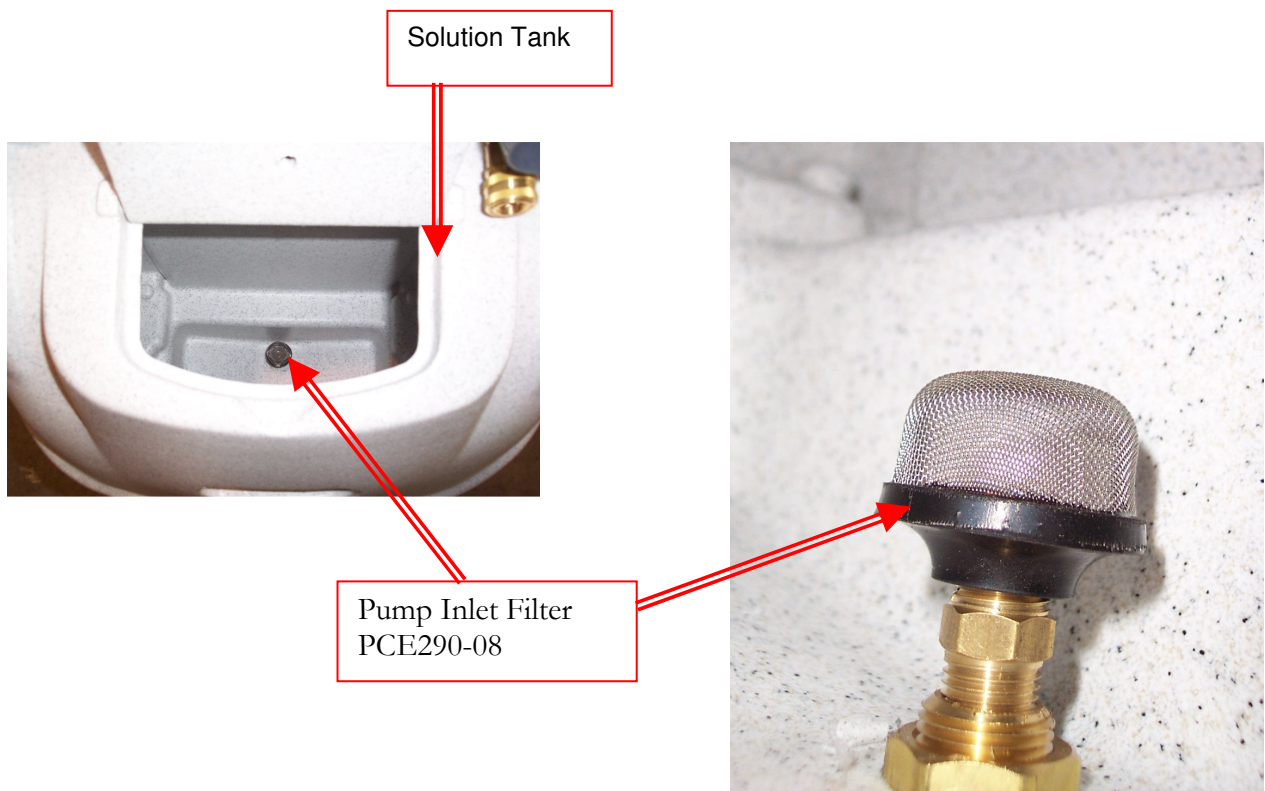

FLUSH CHEMICAL SYSTEM: (With optional Auto-Fill System Only)

Chemical build-up in the chemical system can prevent the system from drawing chemical.

- Rinse the chemical system with fresh water
(For heavy chemical build-up, a mild acid can be added to the rinse.)
- Remove the chemical feed hose from the solution tank and place the end of the hose in a bucket of fresh water or mild acid solution.
- Connect the Auto-Fill Water Supply Hose to the water inlet (male quick connect) on the front of the machine.
- Connect the other end of the hose to a water faucet and turn on the water. Let the water flow into the tank until you are sure the rinse solution has been drawn through the proportioner and mixed with the incoming water. The metering tip can be removed from the proportioner to speed up the process.
- Once the rinse solution has been drawn through the proportioner, turn off the water faucet and disconnect the Auto-Fill Water Supply Hose.
- Plug in Cord #1, connect the vacuum hose to the vacuum barb, turn on vacuum #1, and use the vacuum hose to remove the water from the solution tank.
- When the solution tank has been emptied, turn off the vacuum and unplug the power cord.
- Place a bucket under the drain valve and open the drain valve to drain the water from the recovery tank.
- Close the drain valve and dispose of the water.



Place Chemical Feed Hose into Rinse Solution



Connect Auto-Fill Water Supply Hose to machine and faucet

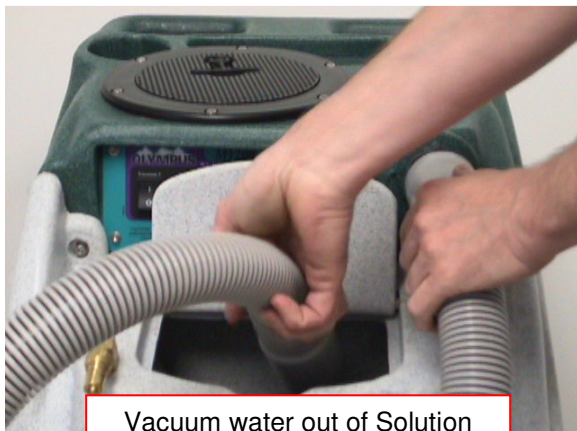

Vacuum water out of Solution Tank

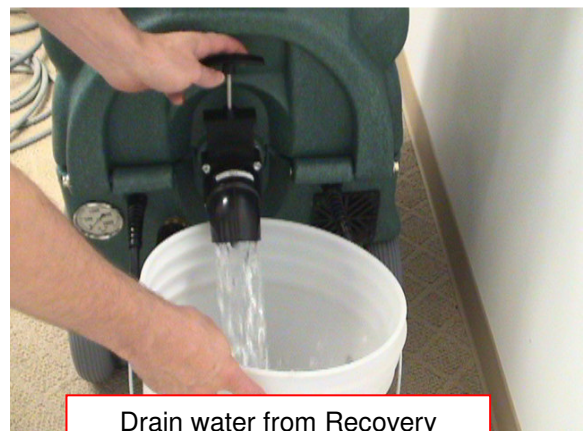

Drain water from Recovery Tank

CLEAN RECOVERY TANK DRAIN

Debris and sand accumulation in the drain valve can damage the valve or prevent it from closing completely. This will result in dirty water leaking from the valve. Use of the Hydro-Filter and regular cleaning of the recovery tank will help prevent this, but occasionally the drain valve will require cleaning or replacement.

Drain the recovery tank before attempting to service the drain valve.

- Unscrew the nuts and remove the four bolts holding the valve assembly to the flange attached to the recovery tank. Unless the flange is damaged, it does not have to be removed from the tank, even when replacing the drain valve.
- Separate the valve body, outlet adapter and gaskets from the flange.



Remove four bolts holding valve assembly to flange fitting

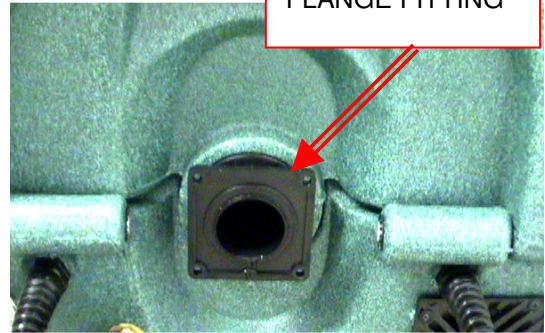

FLANGE FITTING

Unless damaged or leaking between tank and flange, the flange fitting does not have to be removed



DRAIN VALVE – PEA11

VALVE BODY

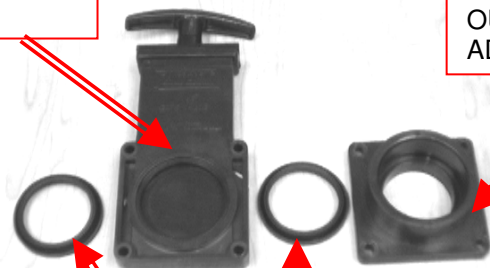

OUTLET ADAPTER

GASKET – NM3019

- Examine the valve body for wear. Check the valve slide for deep scratches. Deep scratches will allow water to flow past gaskets and leak from valve. Replace valve if needed.
- Examine the gaskets and replace if cut, torn or deformed.
- Raised, rounded side of gasket goes toward valve slide. Larger flat sides seat on ring on flange and outlet adapter. Sand and debris will collect in the bottom of the valve body and prevent the slide from going down and seating properly.
- Clean debris out as needed so slide can move to bottom.
- Rinse valve body and reassemble valve body, gaskets and outlet adapter, and place assembly back onto flange fitting.
- Replace four bolts and tighten evenly to secure assembly to flange. Do not over-tighten bolts.



Clean debris from slot in bottom of valve body. Valve slide must be able to slide to bottom.

Storage Prep and Freeze Protection Procedures:

Your Olympus M3-200 must be protected from freezing. Freezing can cause serious damage to the pump, pump-out, auto-fill float valve, and any other component containing water. If the M3-200 is transported or stored in freezing temperatures, the following procedures should be performed.

ALSO, if the M3-200 is stored for an extended period of time, the following procedure should be performed to prevent the pump seals from drying out.

1. In a separate container mix 1/2 gallon of water with 1/2 gallon of automotive radiator anti-freeze. (Ethylene glycol type). Mix well and pour into the solution tank.
2. Connect the pump prime hose to the solution outlet (female quick connect) and perform the pump priming procedure, directing the flow back into the solution tank. When the pump is primed, turn the pump off and disconnect the priming hose.
3. If equipped with Auto-Fill (If not go to step #5); connect the HP solution hose to the solution outlet (female quick connect.) Connect the opposite end of the HP solution hose to the Auto-Fill inlet (male quick connect.) Leave the chemical feed hose in the solution tank and ensure the check valve filter is submerged in the anti-freeze solution. To speed the process the metering tip can be removed. The higher flow rate should reduce the pressure so it is safe for the Auto-Fill system. Be sure float is high enough and fluid level is low enough that float valve does not close. If the valve closes the pressure may build high enough to damage the float valve. **CAUTION: Applying high pressure (over 100psi) to the Auto-Fill system will cause damage to the Float valve and chemical proportioning mechanism.**
4. Turn the solution pump switch to the ON position. Allow the anti-freeze to circulate for 5-10 minutes. Mix and add more anti-freeze solution as needed. Make sure end of chemical feed hose stays submerged in the anti-freeze solution. This will assure that the anti-freeze will be drawn into the proportioning valve. Then turn the solution pump off.
5. Connect any cleaning tools that will be stored with the M3-200. Turn the solution pump switch to the ON position. Direct tool spray back into the solution tank or into a bucket. Turn the solution pump off and repeat for all tools to be protected.
6. Turn the solution pump switch to the OFF position.
7. Use the vacuum hose to vacuum the remaining anti-freeze solution out of the solution tank and bucket.
8. If equipped with Auto Pump-Out (If not go to step #10); remove the cap from the waste-pump out outlet fitting on the back of the machine. Connect a hose to a drain or hold a bucket up to the fitting to catch the pump-out flow.
9. Remove the lid from the recovery tank. Turn the Waste Pump switch to the ON position and lift the float switch to engage the pump-out. Lower the float and turn off the Waste Pump Switch as soon as you see anti-freeze flowing from the outlet fitting or hose.
10. Drain the remaining anti-freeze solution from the recovery tank and the machine is ready for storage.

RETURNING THE M3-200 TO SERVICE AFTER STORAGE OR FREEZE PROTECTION:

To return the M3-200 to service, the anti-freeze must be flushed from the machine. Flush the anti-freeze out of the machine by repeating the procedures above using fresh water in place of anti-freeze.

Parts

Replacement parts available for repair of your M3-200

M3-200 PUMP – AP50 PARTS ASSEMBLY

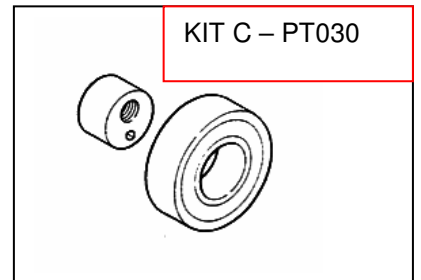
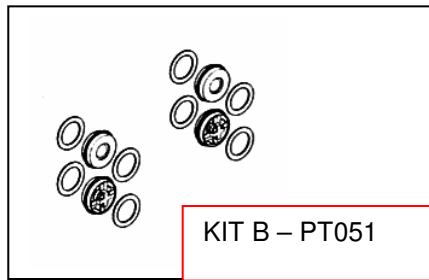
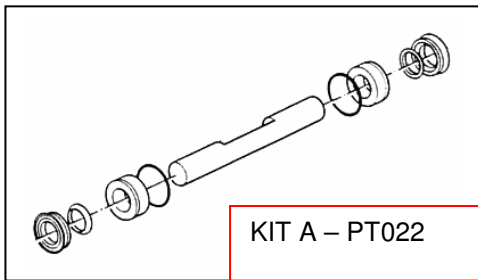
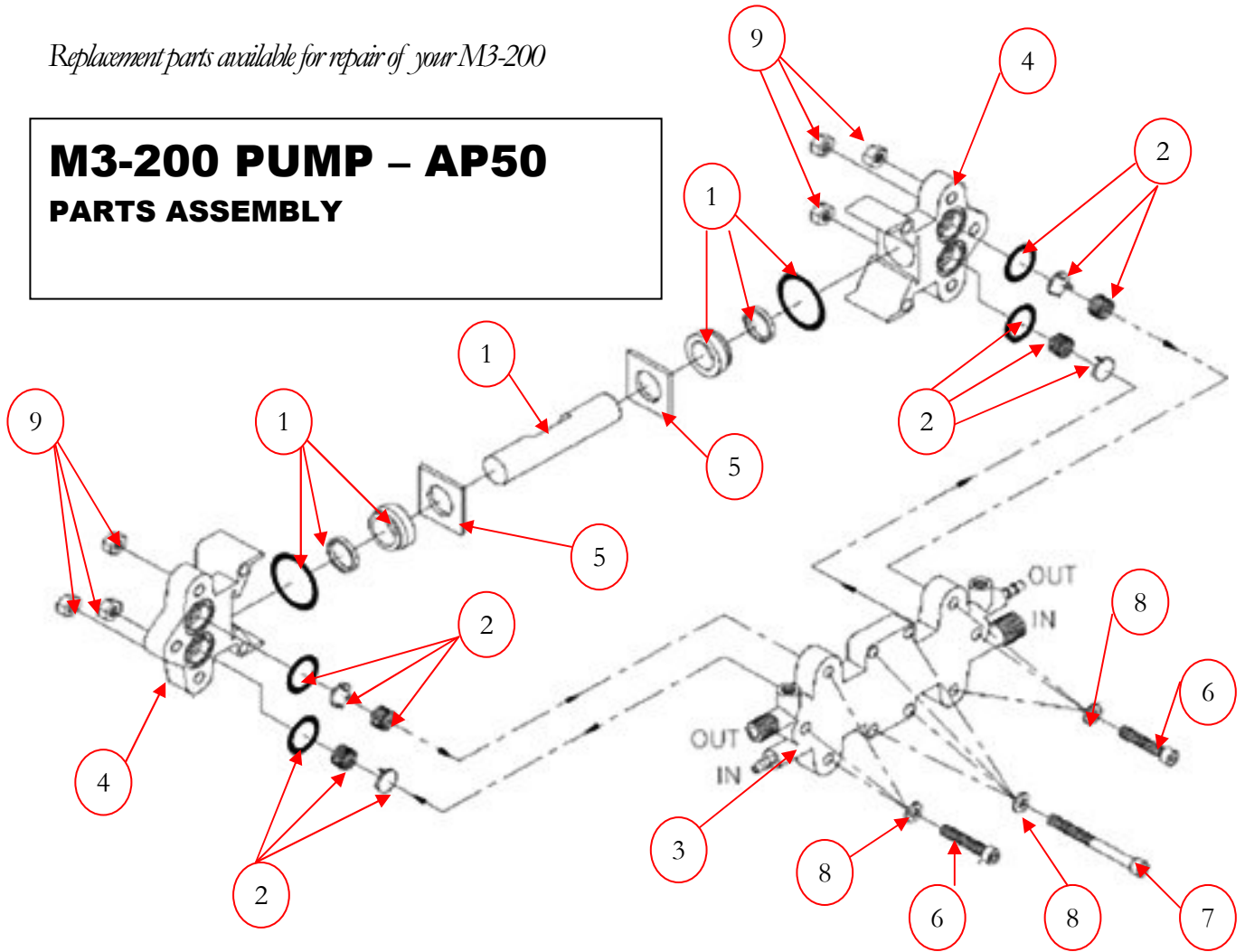

PUMPTEC #114 PUMP – AP50

ITEM	DESCRIPTION	QTY	PART NUMBER
1	KIT A PLUNGER & SEALS	1	PT022
2	KIT B VALVES & O-RINGS	1	PT051
NS	KIT C CAM & BEARING	1	PT030
3	MANIFOLD	1	0114-0004-3110
4	PUMP HEAD	2	0114-0002-0111
5	RETAINER PLATE	2	0111-0014-0001
6	HEAD BOLT	6	BOLT-1/4-20 X 1 1/4-SHCS-SS
7	MOUNT BOLT	4	BOLT-1/4-20 X 2 1/2-SHCS-SS
8	WASHER FLAT M6 STAINLESS STEEL	10	WSH-FLAT-M6-SS
9	NUT 1/4-20 NYLOCK – HEAD BOLT	6	NUT-1/4-20-NYLOC-ZP
NS	PUMP COMPLETE - WITH MOTOR	1	AP50
NS	PUMP COMPLETE - WITHOUT MOTOR	1	PT050
NS	MOTOR	1	PT061

PRESSURE REGULATOR – PT048

	DESCRIPTION
1	REGULATOR COMPLETE (1683-5656)
2	REGULATOR BODY
3	PISTON
4	PISTON SEAL
5	SPRING PLATE
6	SPRING
7	KNOB
NS	REPAIR KIT INCLUDES # 3 & 4

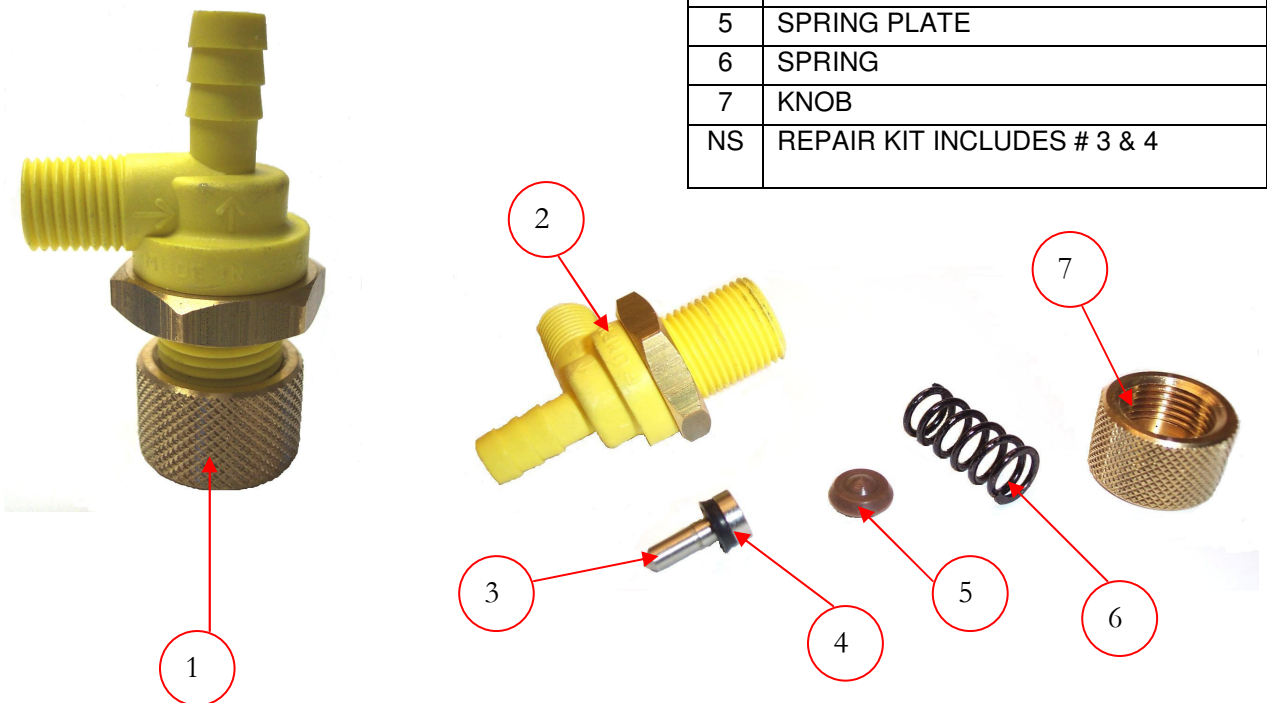

OLYMPUS AUTO-FILL FLOAT VALVE ASSEMBLY (Optional)

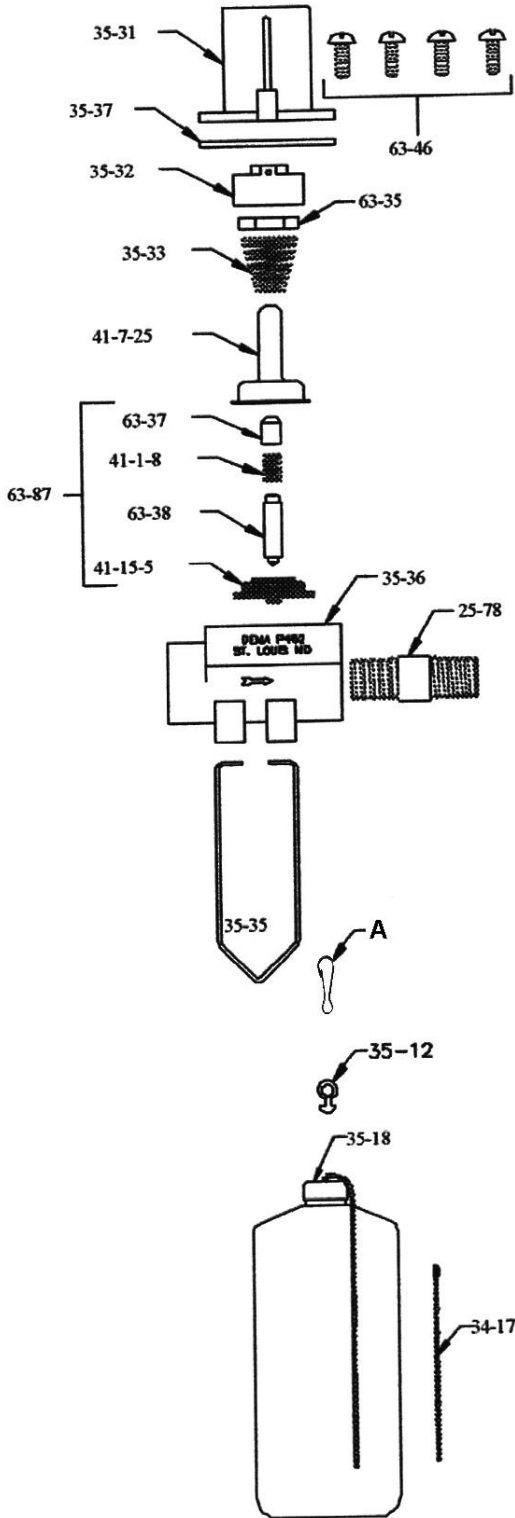

Part Number	Description
16-3	3' Discharge Tubing
25-78	Pipe Nipple
34-17	16" Chain with Connector
34-22	Backflow Preventer
35-12	Float Hanger Clip – NM5452
A	Snap Clip – NM5450
35-18	Float Assembly – PHY005-003
35-31	Magnet Housing
35-32	Magnet Holder
35-33	Spring
35-35	Float Hanger Wire – PDE35-42
35-36	Valve Body
35-37	Flange
41-1-8	Spring
41-7-25	Enclosing Tube
41-15-5	Diaphragm
61-121	Elbow 90° Street 1/4"
61-122	Adapter
61-107-2	Ceramic Weight
61-22-3	Proportioner – PDE61-22-3
63-35	Magnet
63-37	Spacer
63-38	Plunger
63-46	Screw 8-18 x 1/2" (4 req.)
63-87	Valve Repair Kit - PDE63-87 (Includes: 41-1-8, 41-15-5, 63-37 & 63-38)
100-3	Rubber Washer
100-11P	Foot Valve – Filter – PDE100-11P
100-12	8' x 1/4" Plastic Tubing – XAF1
100-15	Metering Tip - Turquoise

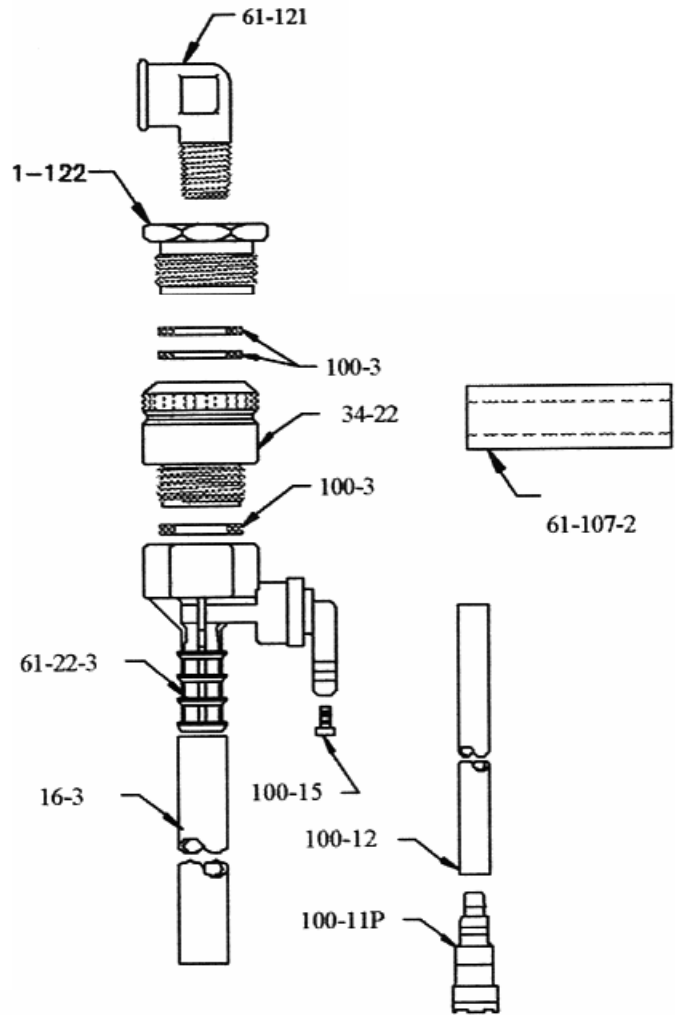

SOLUTION TANK

With Auto Fill Option

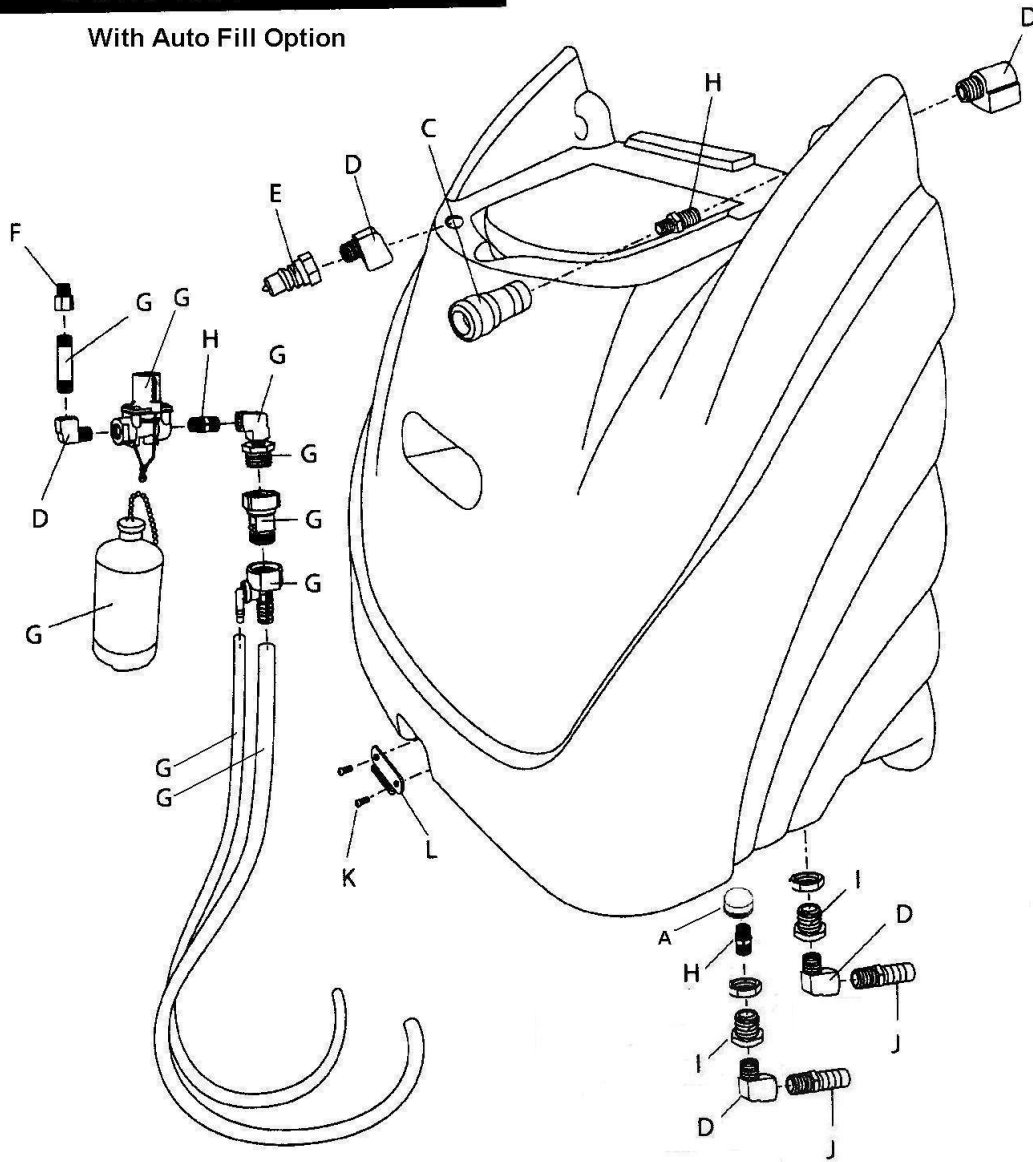

ITEM	PART #	DESCRIPTION	QTY	ITEM	PART #	DESCRIPTION	QTY
A	PCE290-08	ACORN STRAINER 1/4" FPT		I	NM5087	BULKHEAD FITTING 1/4"	2
				J	BR020	BARB 3/8" x 1/4" MPT	2
C	AH101B	QUICK CONNECT 1/4" FM	1	K	NM5023	SCREW 8-32 x 3/8" B	2
D	BR282	ELBOW 90 - 1/4" STREET	5	L	NS121	LATCH HOOK	1
E	AH102B	QUICK CONNECT 1/4" M	1				
F	BR174	ADAPTER 1/4" MPT x 1/4" FPT BR	1				
G	NM5055	FLOAT VALVE ASSY W/CHEM	1				
H	BR072	NIPPLE 1/4" HEX BRASS	3				

SOLUTION TANK INTERNAL

Shown with Auto Fill Option

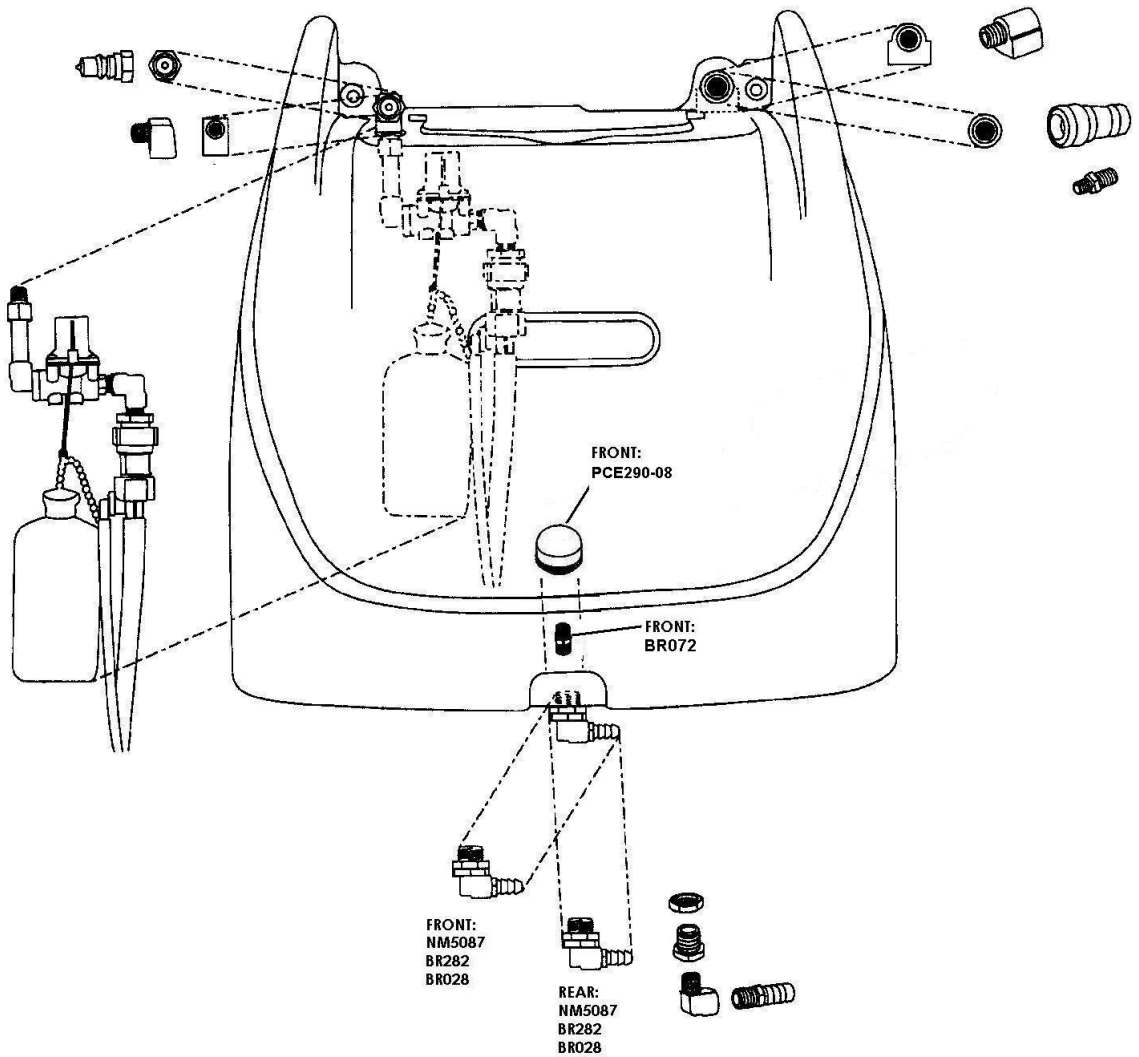

SOLUTION TANK

Standard

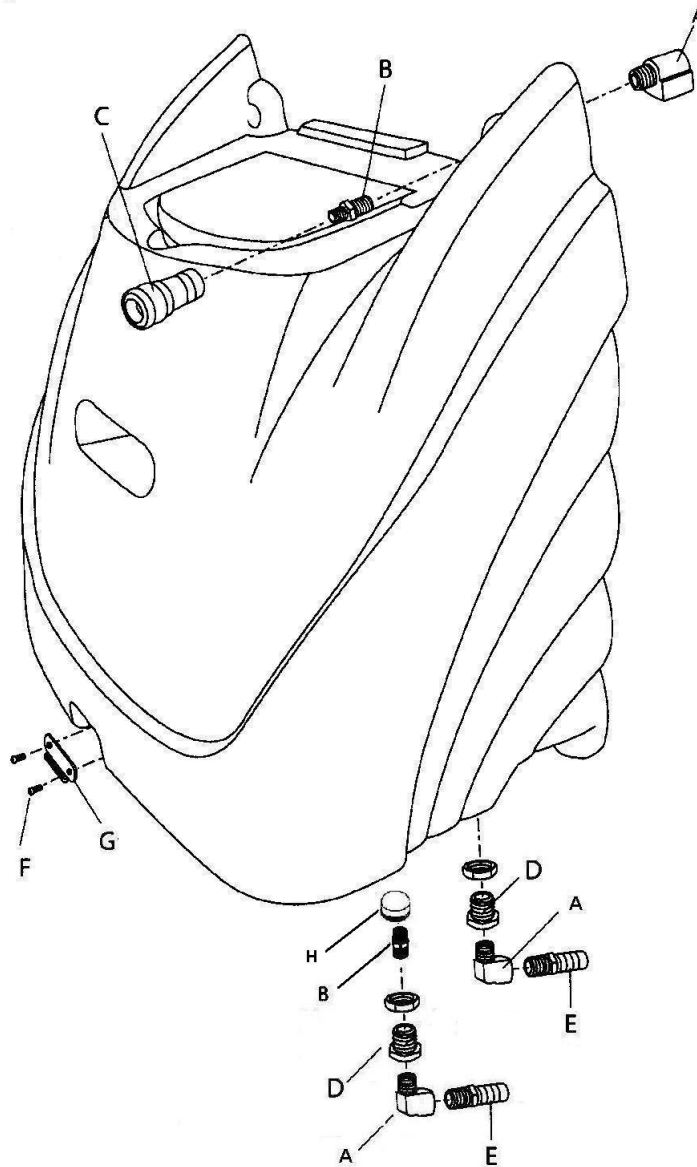

ITEM	PART #	DESCRIPTION	QTY	ITEM	PART #	DESCRIPTION	QTY
A	BR282	ELBOW 90 - 1/4" STREET	3	F	NM5023	SCREW 8-32 x 3/8" B	2
B	BR072	NIPPLE 1/4" HEX BRASS	2	G	NS121	LATCH HOOK	1
C	AH101B	QUICK CONNECT 1/4" FM	1	H	PCE290-08	ACORN STRAINER 1/4" FPT	1
D	NM5087	BULKHEAD FITTING 1/4"	2				
E	BR020	BARB 3/8" x 1/4" MPT	2				

WASTE TANK

Shown with Auto Pump Out Option

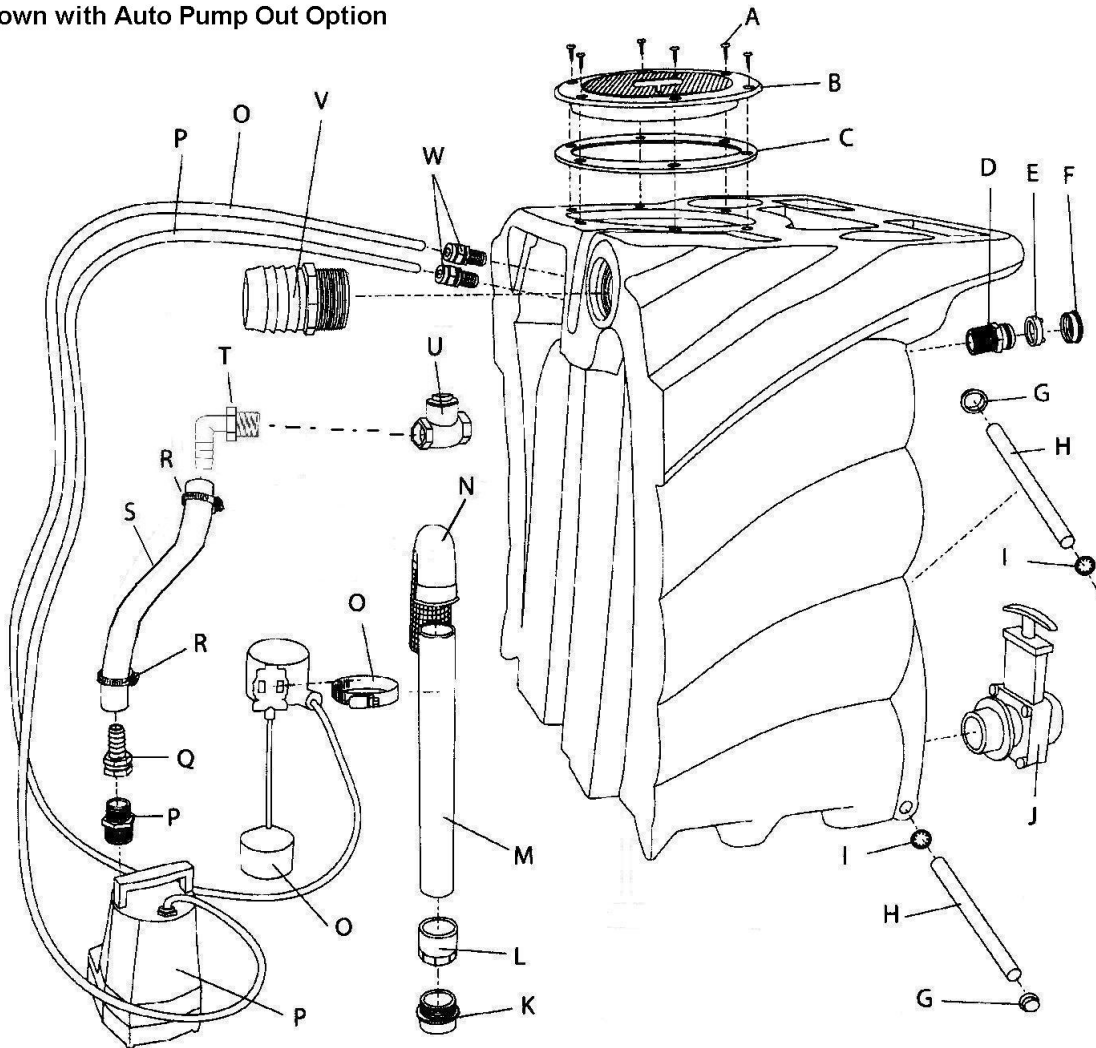

ITEM	PART #	DESCRIPTION	QTY	ITEM	PART #	DESCRIPTION	QTY
A	PA187	SCREW #10 x 5/8" SH	6	O	NM5054	SWITCH FLOAT STRAIGHT	1
B	NM5004	LID ASSEMBLY WASTER TANK	1	P	NM5053	PUMP LITTLE GIANT	1
C	NM5059	GASKET WASTE TANK LID	1	Q	BR333	BARB 3/4" x 3/4" FGH	1
D	BR319	ADAPTER 3/4" MPT X MGH	1	R	PH09	CLAMP HOSE SCREW 9/16"	2
E	BR600	GASKET	1	S	NM5056	HOSE 3/4" WATER BLACK	12"
F	BR325	CAP CARDEN HOSE BRASS	1	T	PA110	ELBOW 90 BARB 3/4" x 3/4" MP	1
G	NM5010	CAP AXLE OLYMPUS REAR	2	U	NM5052	CHECK VALVE 3/4" SWING	1
H	NM5013	HINGE POST	2	V	AH69	BARB 2" x 1-1/2" MPT	1
I	NM5026	HINGE RETAINING CLIP	2	W	NM5051	STRAIN RELIEF	2
J	PEA11	VALVE 1-1/2" MPT GATE	1				
K	NM5042	ADAPTER 1-1/2" MPT X 1-1/2" MS	1				
L	NM5081	ADAPTER 1-1/2" FPT X 1-1/2" FS	1				
M	NM5036	PIPE 1-1/2" X 17" A B S	16"				
N	NM5037	FLOAT & FILTER CAGE	1				

WASTE TANK SIDE INTERNAL VIEW

Shown with Auto Pump Out Option

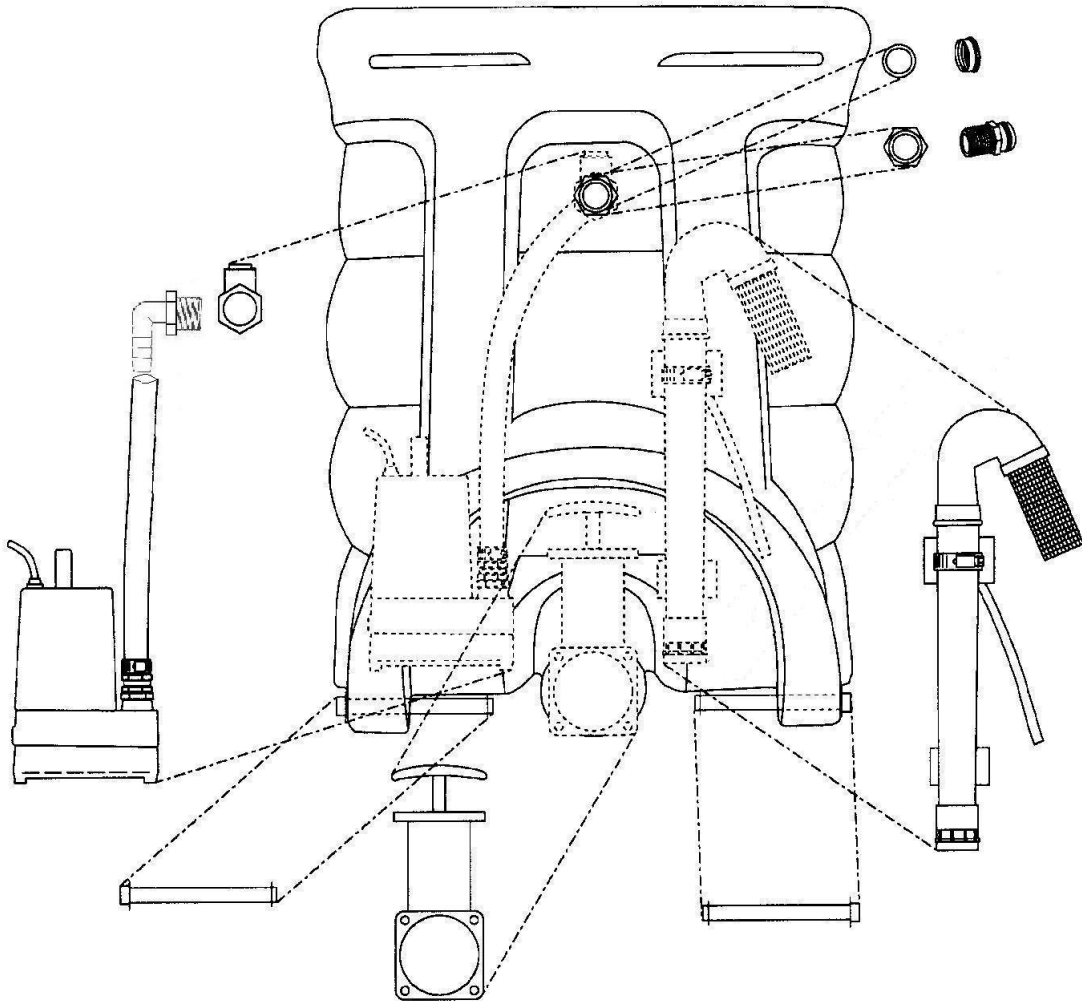

WASTE TANK WITHOUT PUMPOUT

M200H

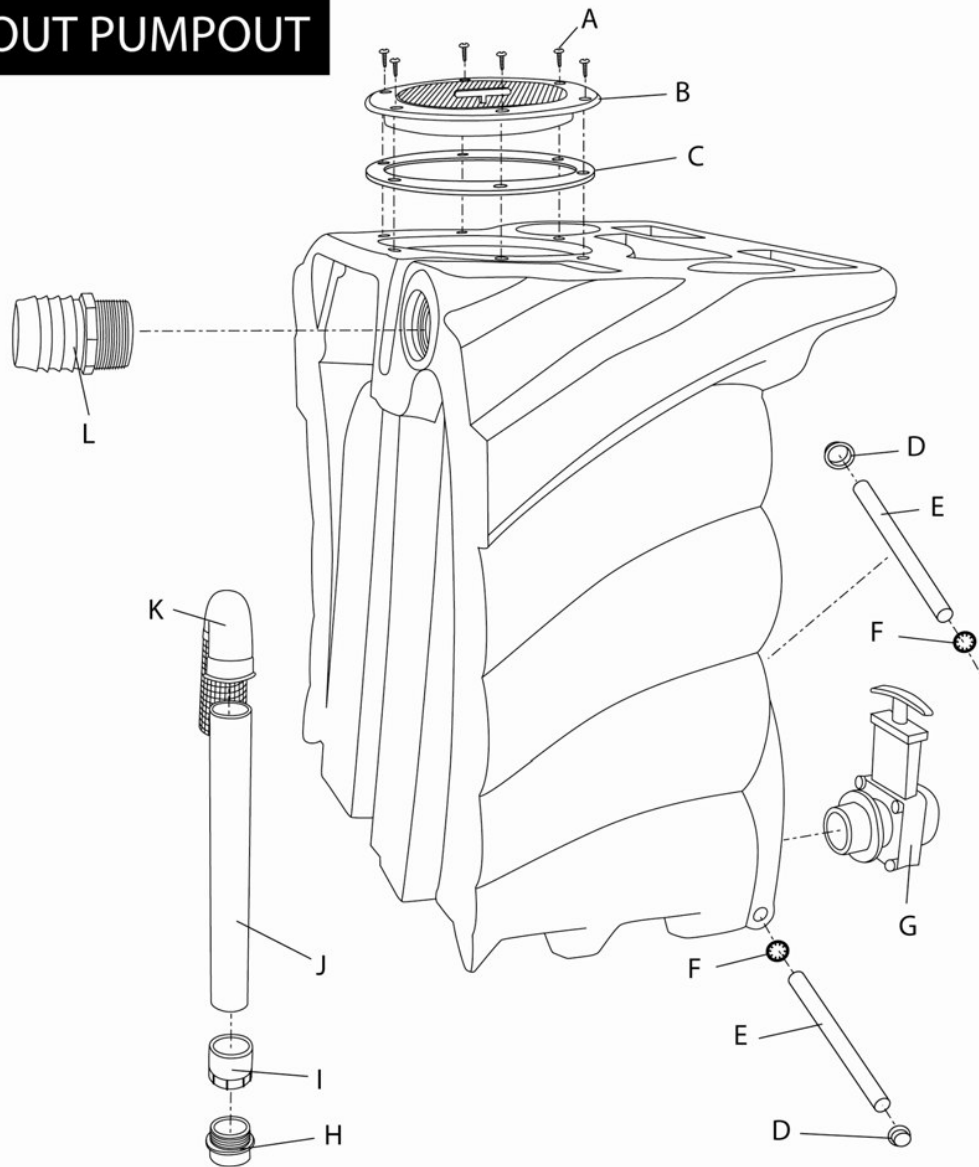

ITEM	PART #	DESCRIPTION	QTY	ITEM	PART #	DESCRIPTION	QTY
A	PA187	SCREW #10 x 5/8" SH	6	G	PEA11	VALVE 1-1/2" MPT GA	1
B	NM5004	LID ASSEMBLY WASTER TANK	1	H	NM5042	ADAPTER 1-1/2" MPTX	1
C	NM5059	GASKET WASTE TANK L	1	I	NM5081	ADAPTER 1-1/2" FPT X	1
D	NM5010	CAP AXLE OLYMPUS RE	2	J	NM5036	PIPE 1-1/2" X 17" A	16"
E	NM5013	HINGE POST	2	K	NM5037	FLOAT & FILTER CAGE	1
F	NM5026	HINGE RETAINING CLI	2	L	AH69	BARB 2" x 1-1/2" MP	1

BASE WITH VACUUMS & COMPONENTS

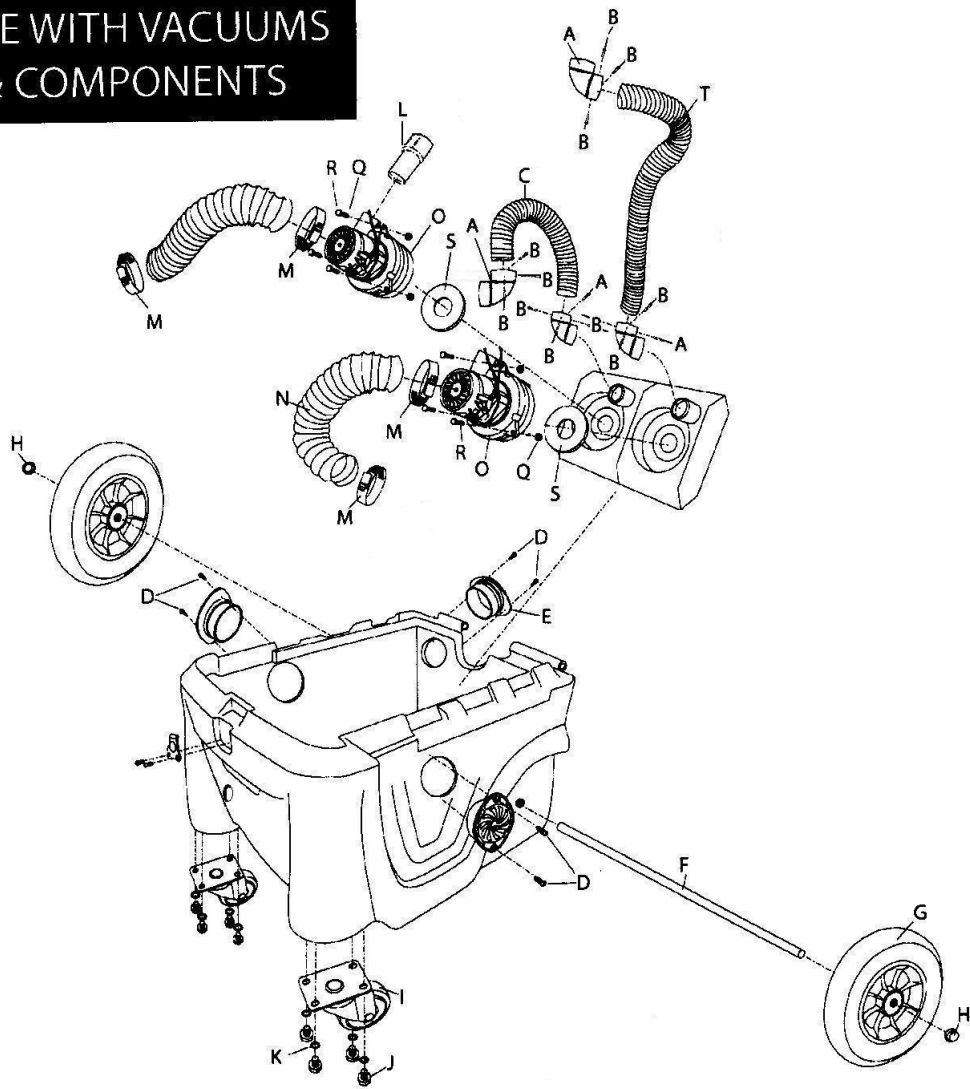

ITEM	PART #	DESCRIPTION	QTY	ITEM	PART #	DESCRIPTION	QTY
A	NM5041	ELBOW 90 - 1-1/2" ABS	4	K	NM5014	WASHER LOCK - CASTER	8
B	NM5025	RIVET HOSE ELBOW	12	L	AH42	CUFF 1-1/2" HOSE	1
C	NM5050	VAC HOSE 1-1/2" WIRE REINFORCE	21"	M	PHO14	CLAMP HOSE SCREW 3"	4
D	PA184	SCREW 8x3/8 SHEET METAL	12	N	NM5018	DUCT 3" x 18" VINYL BLACK	2
E	NM5015	GRATE VAC EXHAUST	3	O	AV14	VAC MOTOR 5.7 3 STAGE	2
F	NM5011	AXLE OLYMPUS REAR WHEEL	1	P			
G	NM5002	REAR OLYMPUS WHEEL	2	Q	NM5033	WASHER MANIFOLD BOTLS	6
H	NM5010	REAR WHEEL AXLE CAP	2	R	NM5089	SCREW 10-32x1-1/2" SS	6
I	NM5003	FRONT CASTER	2	S	PA010	GASKET VAC MOTOR 5.7"	2
J	NM5012	SCREW 1/4-20 x 1" HX HD	8	T	NM5050	VAC HOSE 1-1/2" WIRE REINFORCE	24"

BASE WITH PUMP & COMPONENTS

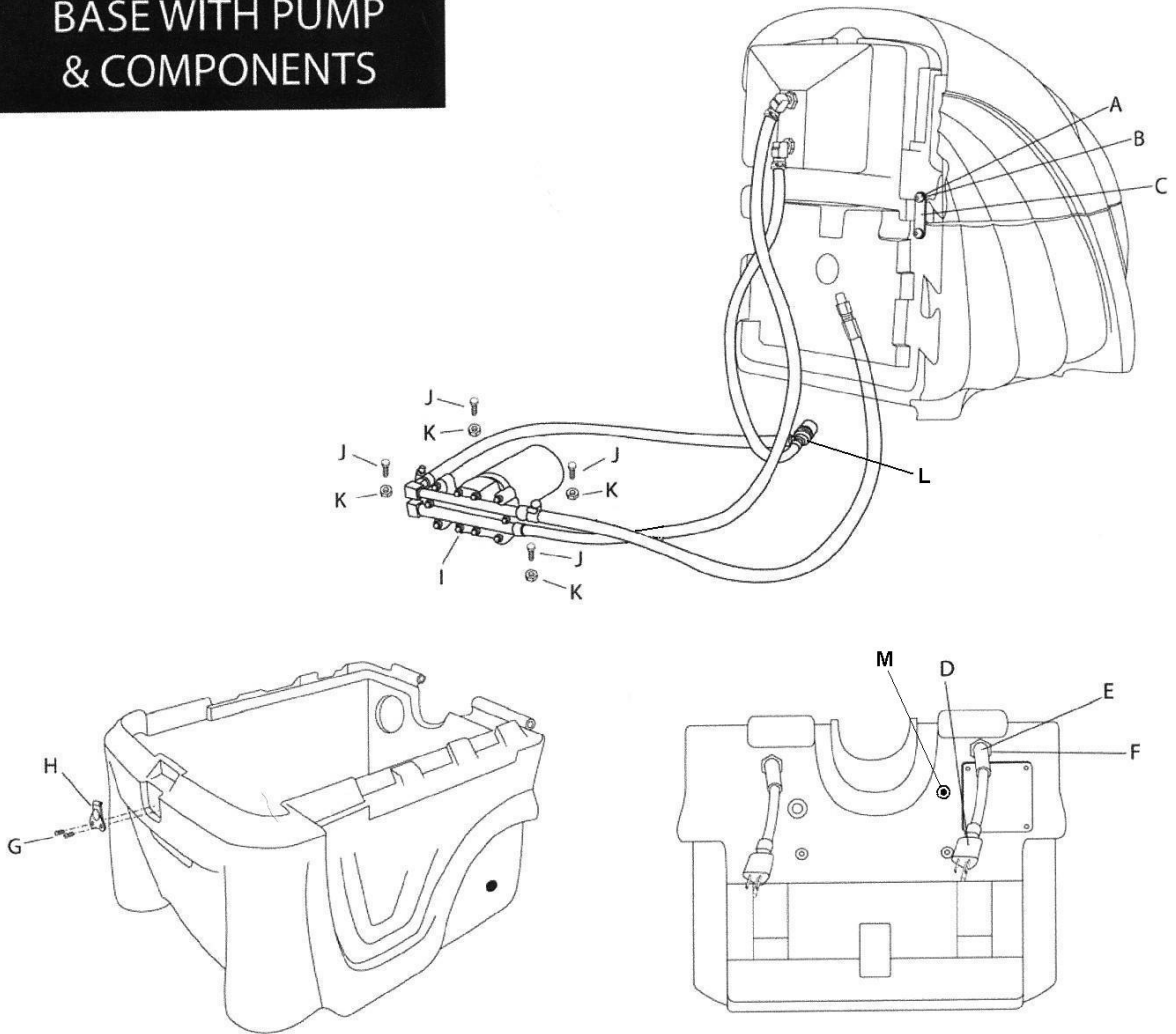

REAR VIEW

ITEM	PART #	DESCRIPTION	QTY	ITEM	PART #	DESCRIPTION	QTY
A	NM5028	SCREW 1/4-20x1/2" SS SOC HD	4	G	NM5023	SCREW 8-32x3/8" BH SOC SS	2
B	NM5030	WASHER 1/4" FLAT BLACK	4	H	NS120	LATCH	1
C	NM5027	BRACKET SOL/REC TANK	2	I	AP50	PUMPTec 200 PSI PUMP	1
D	NM5009	CORD 12/3x2' W/MALE END	2	J	NM5034	SCREW 1/4-20x1" HX HD	4
E	NM5038	STRAIN RELIEF	2	K	NM4003	NUT 1/4-20 HEX SS	4
F	NM5039	NUT STRAIN RELIEF	2	L	PT048	200PSI PRESSURE REG	1
				M	NM5105	5AMP CIRCUIT BREAKER	1

Limited Warranty

Section

4

Your Olympus M3-200 is designed to give you years of reliable service. If a problem should arise use the troubleshooting section in the operation manual to diagnose and correct the problem if possible.

If you are unable to determine the cause or solution to the problem contact your distributor or Hydro-Force for assistance.

Hydro-Force warrants the roto-molded tanks and base of the Olympus M3-200 to be free from defects in material or workmanship for five years from the date of purchase.

All other components of the Olympus M3-200 are warranted to be free of defects in material and workmanship for one year from the date of purchase.

During the warranty period, Hydro-Force will, at its option repair or replace components which prove to be defective. This warranty does not provide for replacement of complete units due to defective components. Any costs for transportation or related service labor are not covered in this warranty. Replacement parts are warranted only for the remainder of the original warranty period.

This warranty shall not apply to defects resulting from improper operation, lack of maintenance, unauthorized modification, chemical incompatibility, misuse, abuse or exposure to freezing temperature conditions. It does not cover normal wear items such as o-rings, valve seals, pump seals, hoses, jets, cords, batteries, or other items which require replacement as a result of ordinary usage.

To obtain warranty service for the Olympus M3-200, contact your distributor or Hydro-Force. If the extractor must be returned to Hydro-Force or an authorized service center, the purchaser shall prepay shipping charges for products returned for warranty service. No returned items will be accepted by Hydro-Force without prior authorization. All returns must have a return authorization number, issued by Hydro-Force, clearly marked on the exterior of the package.

Hydro-Force makes no other warranty either expressed or implied with respect to this product.

The remedies provided herein are the purchaser's sole and exclusive remedies. In no event shall Hydro-Force be liable for any direct, indirect, special, incidental or consequential damages.

This warranty gives you specific legal rights. You may also have other rights which vary from jurisdiction to jurisdiction.